

# A800R

1/10-SCALE TOURING CAR

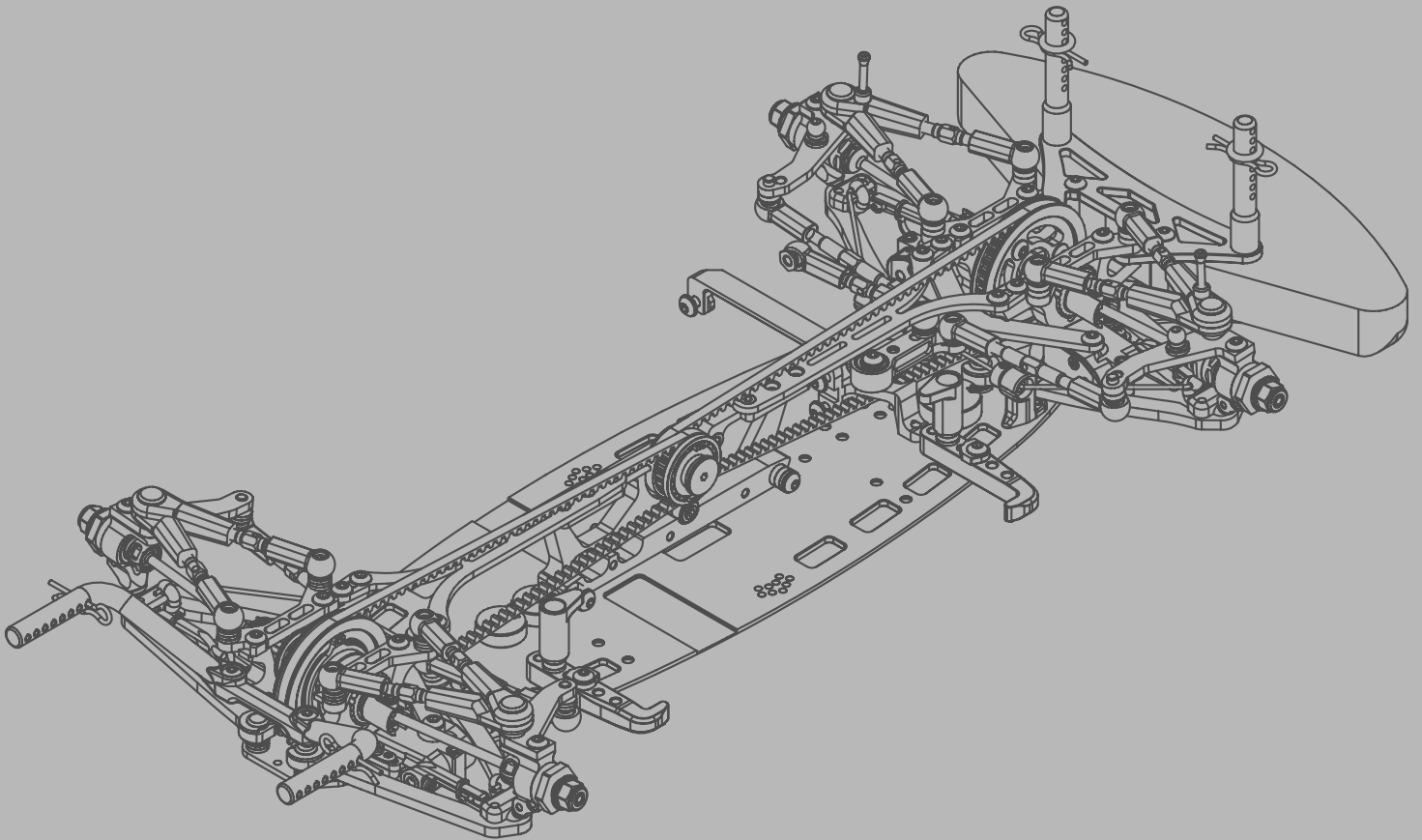

**INSTRUCTION MANUAL**

## INTRODUCTION

Congratulations on purchasing your Awesomatix car!  
The A800R car was produced by UAB “Awesomatix” company.  
The A800R car utilises many unique features, including some patented innovations.

## BEFORE YOU START

The A800R car is the high-quality, innovative 1/10-scale touring car and should be built only by persons with previous experience building R/C model racing cars.

This is not a toy and is not intended for use by children without direct supervision of a responsible, knowledgeable adult. Read the instruction manual carefully and fully understand it before beginning assembly. If you have any problems or questions please do not hesitate to contact the Awesomatix team at [support@awesomatix.com](mailto:support@awesomatix.com). If, for any reason, you decide that you do not want your A800R car you must not begin assembly.

Your A800R car cannot be returned to UAB “Awesomatix” for a refund or exchange if it has been fully or partially assembled.

This kit is a radio controlled model racing product and could cause harm and personal injury.

The A800R car is designed for use on r/c car race tracks. It should not be used in general public areas.

UAB “Awesomatix” accepts no responsibility for any injuries caused by making or using this kit.

Due to policy of continuous product development the exact specifications of the kit may vary.

UAB “Awesomatix” do reserve all rights to change any specifications without prior notice. All rights reserved.

## ASSEMBLY NOTES

Before starting each build-stage check that you have the right quantity and size of items for the build-stage. To assist you with the assembly of your A800R car we have included full-size images of all the small hardware parts laid out so that you can place items on top of the images to check are they correct size/length. You can find the useful tips and pictures of A800R assembling on the internet site: <http://site.petitrc.com/reglages/awesomatix/SetupSheetsAwesomatixA800R.html>

## GENERAL PRECAUTIONS

- Many of the items in this kit are small enough to be accidentally swallowed and are therefore potential choking hazards, making them potentially fatal. Please ensure that when assembling the kit you do so out of the reach of small/young children.
- Take care when building, as some parts may have sharp edges.
- Please read this manual carefully to understand which ancillary items (tools, electrics, electronics etc) are used with this kit. UAB “Awesomatix” accepts no responsibility for the operation of any such ancillary items.
- Exercise care when using tools and sharp instruments.
- Follow the operating instructions for the radio equipment at all times.
- Never touch rotating parts of the car as this may cause injury.
- Keep the wheels of the model off the ground when checking the operation of the radio equipment.
- To prevent any serious personal injury and/or damage to property, be responsible when operating all remote controlled models.
- The model car is not intended for use on roads or areas where its operation can conflict with or disrupt pedestrian or vehicular traffic.
- Do not run your car in poor light or if it goes out of sight. Any impairment to your vision may result in damage to your car or, worse, injury to others or their property.
- As a radio controlled device, your car is subject to radio interference from things beyond your control. Any such interference may cause a loss of control of your car so please consider this possibility at all times.
- When not using RC model, always disconnect and remove battery.
- Insulate any exposed electrical wiring to prevent dangerous short circuits. Take maximum care in wiring, connecting and insulating cables. Make sure cables are always connected securely. Check connectors for if they become loose and if so reconnect them securely. Never use R/C models with damaged wires. A damaged wire is extremely dangerous and can cause short-circuits resulting in fire.

## EQUIPMENT RECOMMENDED (NOT INCLUDED)

- Radio Transmitter
- Radio Receiver
- Electronic Speed Control
- Steering Servo
- Servo Horn
- Electric Motor
- Pinion Gear (64 or 48 Pitch)
- Spur Gear (64 or 48 Pitch)
- 7.4 V Li-Po Battery
- 190mm Body Shell
- Touring Car Wheels, Tires, Inserts

## TOOLS RECOMMENDED (NOT INCLUDED)

- 1.5mm, 2.0mm Hex Driver
- 5.5mm, 3/8, 10mm Wrenches
- Callipers
- Hobby Knife
- Camber Gauge
- Ride Height Gauge
- Thread Lock
- 5000 cst Diff Silicone Oil
- 400 cst, 500 cst Silicone Shock Oil
- Joint Grease
- O-Ring Grease

**Note these items at assembling of the car.**

Note the shoulder

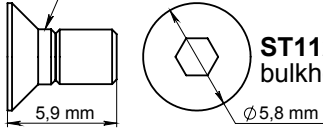

**ST112 screws** - used for fastening only bulkheads and dampers to the lower deck!

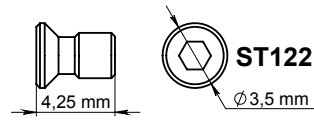

**ST122**

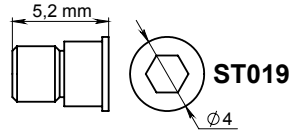

**ST019**



**ST143 with OR1010V o-ring**

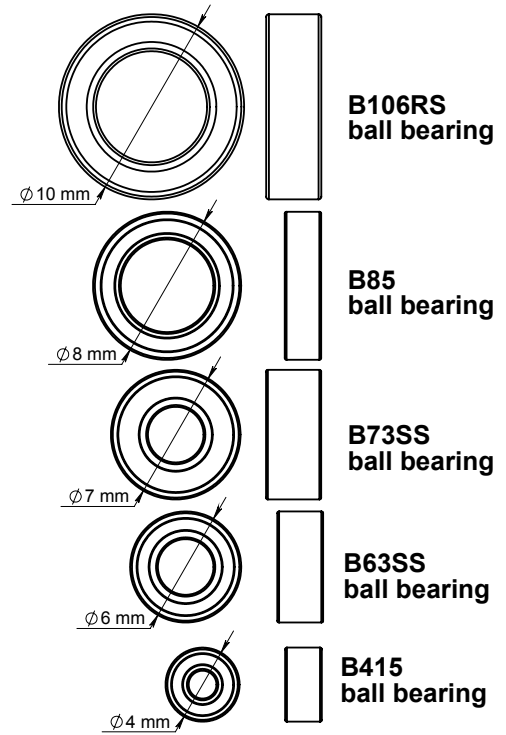

**B106RS**  
ball bearing

**B85**  
ball bearing

**B73SS**  
ball bearing

**B63SS**  
ball bearing

**B415**  
ball bearing

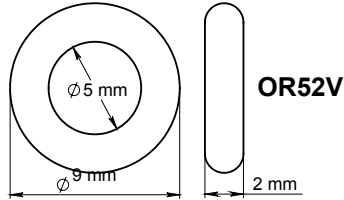

**OR52V**

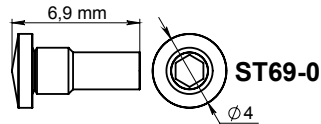

**ST69-0**

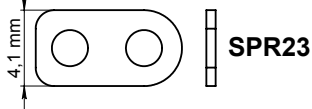

**SPR23**

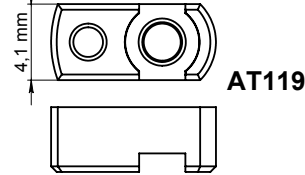

**AT119**

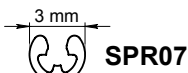

**SPR07**

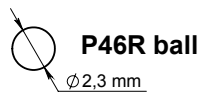

**P46R ball**

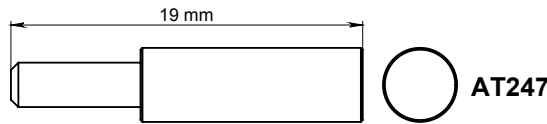

**AT247**

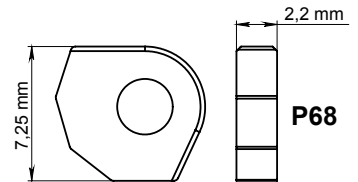

**P68**

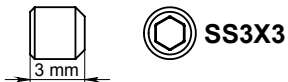

**SS3X3**

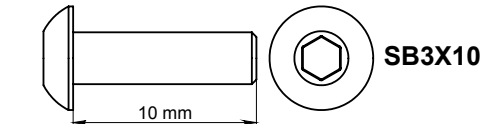

**SB3X10**

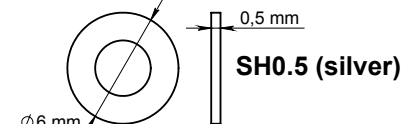

**SH0.5 (silver)**

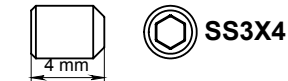

**SS3X4**

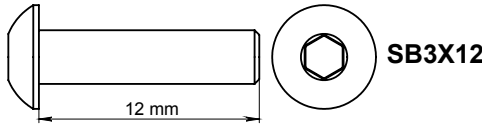

**SB3X12**

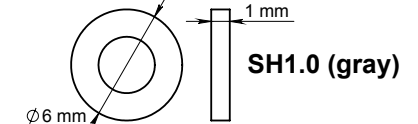

**SH1.0 (gray)**

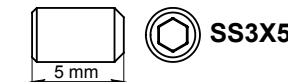

**SS3X5**



**SC2X4**

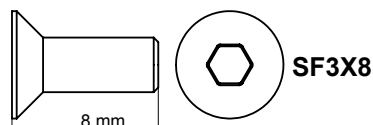

**SF3X8**

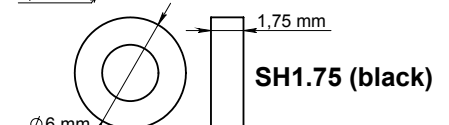

**SH1.75 (black)**



**SC2X6**

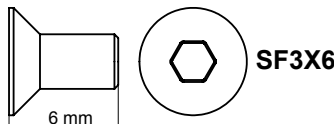

**SF3X6**

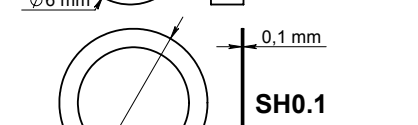

**SH0.1**

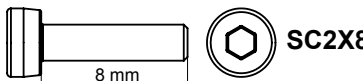

**SC2X8**

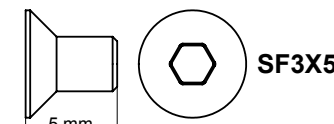

**SF3X5**



**OR2010V**

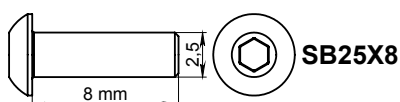

**SB25X8**

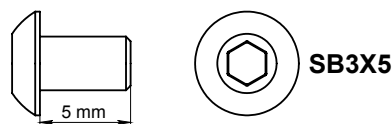

**SB3X5**

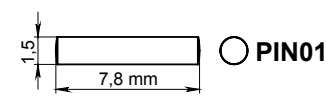

**PIN01**

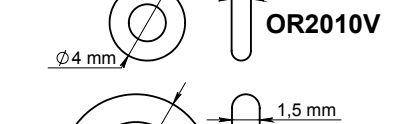

**OR06**

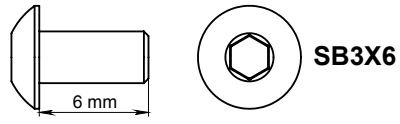

**SB3X6**

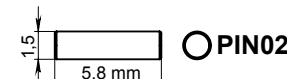

**PIN02**

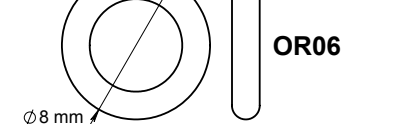

**OR05V**

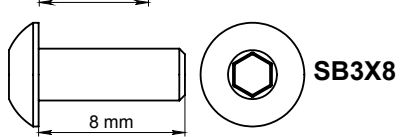

**SB3X8**

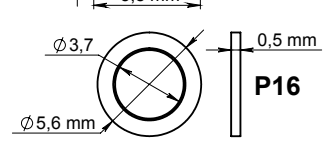

**P16**

## STEP 1 - Assembling of the D3 Dampers

**Note:** As a starting point we recommend 400 cst silicone oil for the front dampers and 500 cst silicone oil for the rear dampers.

- #1** Insert **OR2010V** o-ring into the upper cavity of **AM242R/L** case.  
 Lubricate **ST143** with small amount of the silicon oil. Note that one **OR1010V** o-ring is already factory installed on each **ST143**.  
 Hold **OR2010V** o-ring with forefinger and insert the lubricated **ST143** into **AM242R/L** hole.  
 Rotate and press on **ST143** simultaneously with 1,5mm hex screwdriver so that the pointed tip of **ST143** should pass through **OR2010V** o-ring.

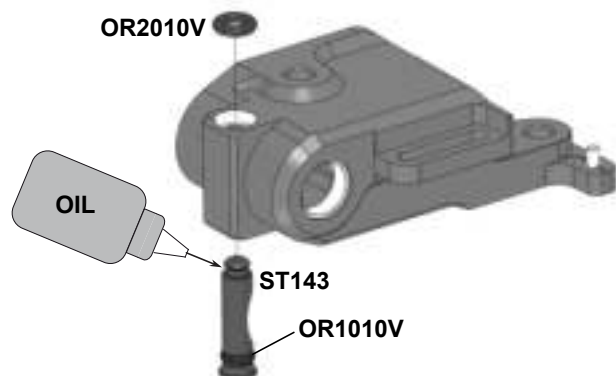

At proper installation **OR2010V** o-ring must occupy the top groove of **ST143**.

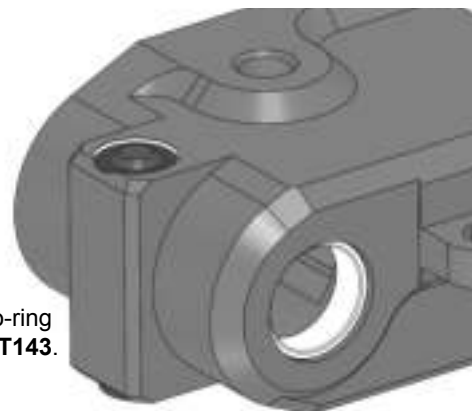

- #2** Turn **ST143** valve into position for further installation of the **AT241** rotor.

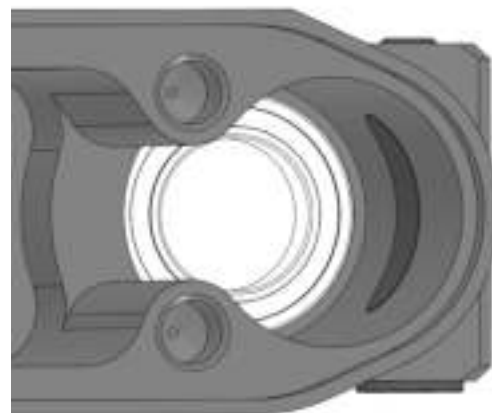

- #3** Put **OR1705V** - the thin 17x0,5mm o-ring into the slot of **AM240** cover. Try don't twist this o-ring at installation into slot.



- #4** Choose the desirable orientation of **AT243** plate before installation - for linear damping mode or for progressive damping mode. Insert **AT243** plate into **AM242** case fully. The fit of the **AT243** can be a bit tight.

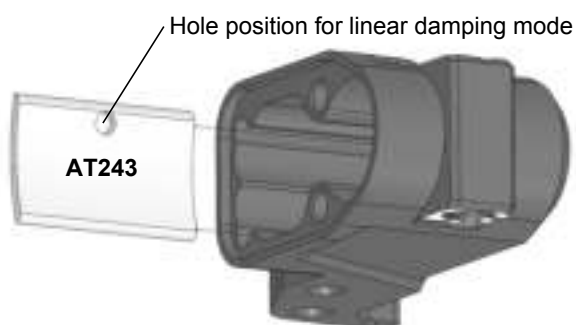

Linear damping mode is recommended for carpet tracks.

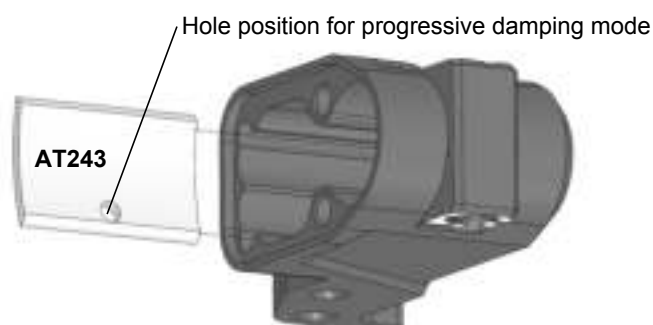

Progressive damping mode is recommended for asphalt tracks.

- #5** Lubricate the outer edge of the **P63** piston with small amount of the “O-ring Grease”. **MXLR** brand o-ring grease is recommended. Don't allow the grease or any other lubricant to get on the **P63** piston leg! Insert **P63** piston into **AT241** on full depth. Insert **AT247** probe into the output hole of **AT241** rotor and shift **P63** piston to the recommended ~7mm position.

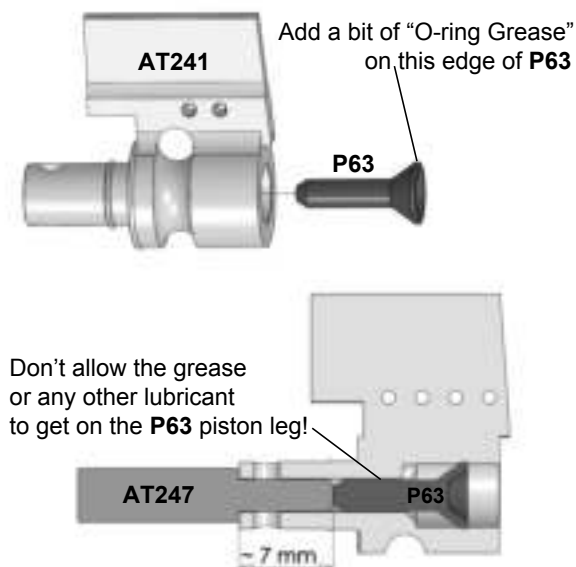

**P263** membrane can be used instead of **P63** piston. Deform **P263** till ~ 4,2 mm size like on the picture and install into **AT241**. Use **AM240** cover as a guage for **P263** positioning in **AT241**. “O-ring Grease” is not needed.

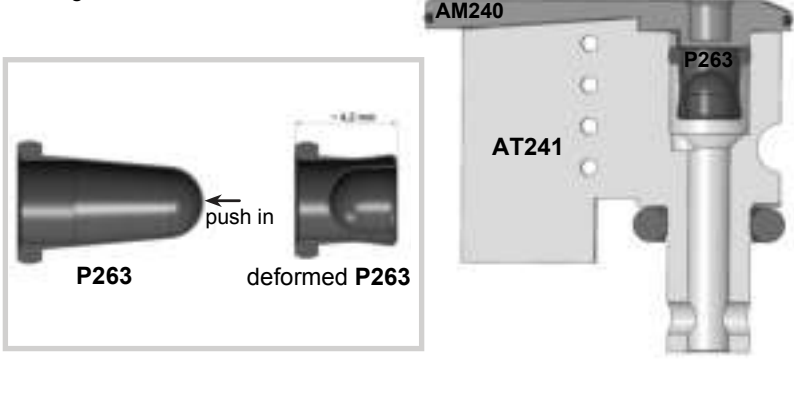

- #6** Put **OR52V** o-ring on **AT241** rotor's shaft and add the silicone oil into the gap under o-ring to fill this gap fully. Insert **AT241** rotor into **AM242** body on full depth.

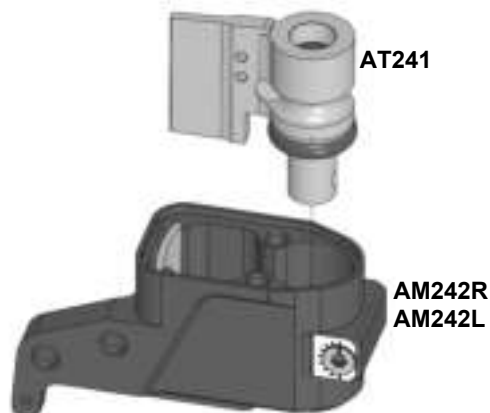
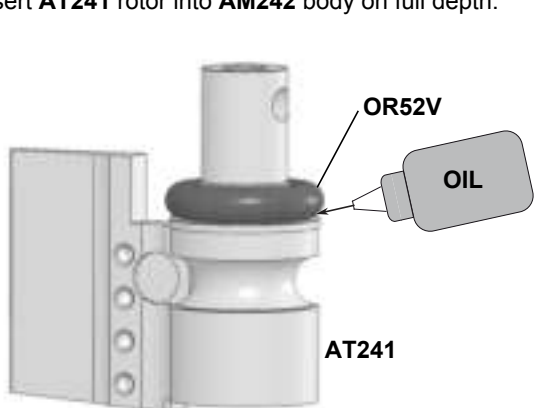

- #7** Prepare the damper's stand for using with the Tamiya style RC Damper Oil Air Remover tool. Screw **P67** stand to three **P14-2** posts (cutted till ~43mm length) or to the air remover's original stand instead one of plates.

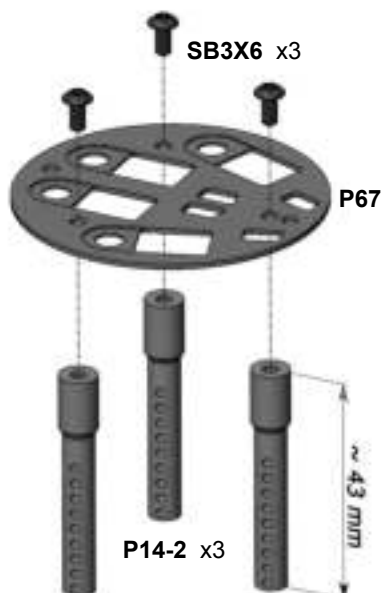

**TIP / Recommendation to use**  
 MAX-02-003 - MXLR Awesomatix A800R ShockVac  
 MAX-01-003 - MXLR O-Ring grease (for P63 & OR52V)

- #8** Install the dampers on the air remover stand and keep them vertically.  
 Add the desirable silicon oil into the damper's inner space. The oil level should reach the top face of **AT243** on this stage. Don't forget to fill by oil the cavity over **P63** piston or over **P263** membrane. Check the narrow slot behind **AT243** and add the oil also there. It's not easy to detect the lack of oil in the slot behind **AT243** so please pay more attention to this.

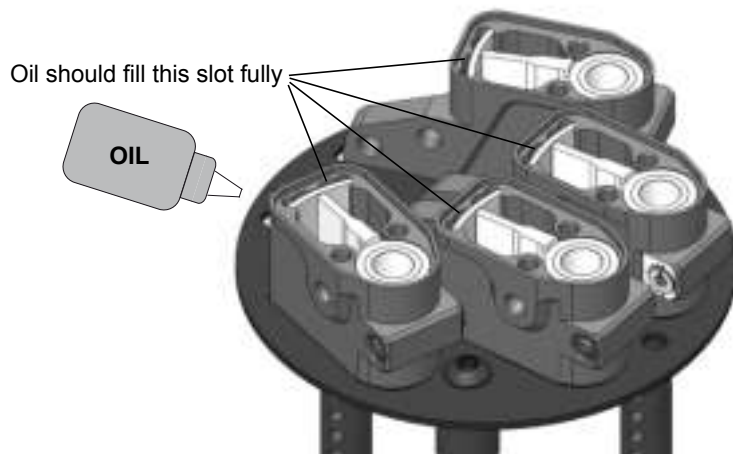

- #9** Vacuum should be applied at least 10 times x 2 minutes. Try to reach the maximum possible level of vacuum on every cycle. There are a lot of small cavities inside dampers that hold air for a long time. The air bubbles remain to go out even after several cycles of "vacuum is on" - "vacuum is off". So please pay maximum attention on the air bubbles removing process.

- #10** Add more oil into damper. The oil level should be a little over the upper edge of **AM242**. Use long M3 screw in the special hole of **AM240** for holding. **AM240** cover should be inserted 100% horizontally and slowly to allow the oil to fill the cavity of **AM240** and to oust the air through two through holes of **AM240**. **AM240** should dive into oil under its weight on this stage. Next press on **AM240** with finger slowly and submerge **AM240** cover full way into the pocket of **AM242** body.

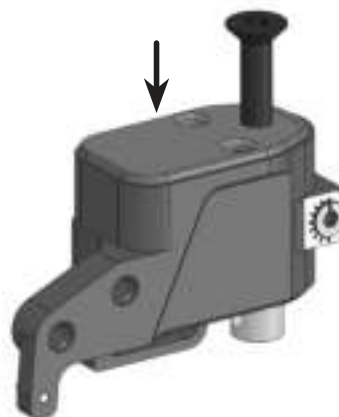
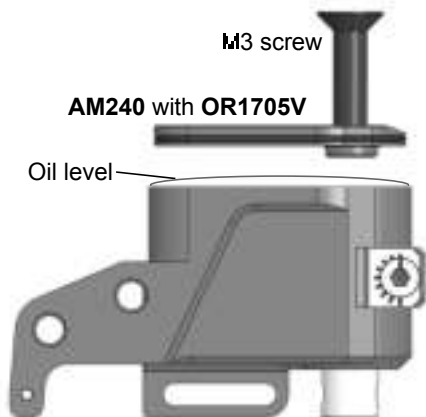

- #11** Keep the damper vertically on table and screw two **ST122** screws. Please don't overtighten screws to avoid the thread stripping!  
 Wipe excess oil off the damper body with paper towels and remove M3 screw.



**#12** Install **ST102F** (longer part) on the front dampers and **ST102R** (shorter part) on the rear dampers. Keep the damper vertically and swing **AT241** rotor few times in both directions. In case you feel the air bubbles inside the damper remove **AM240** cover, add the oil into the damper and repeat the **AM240** installation process.

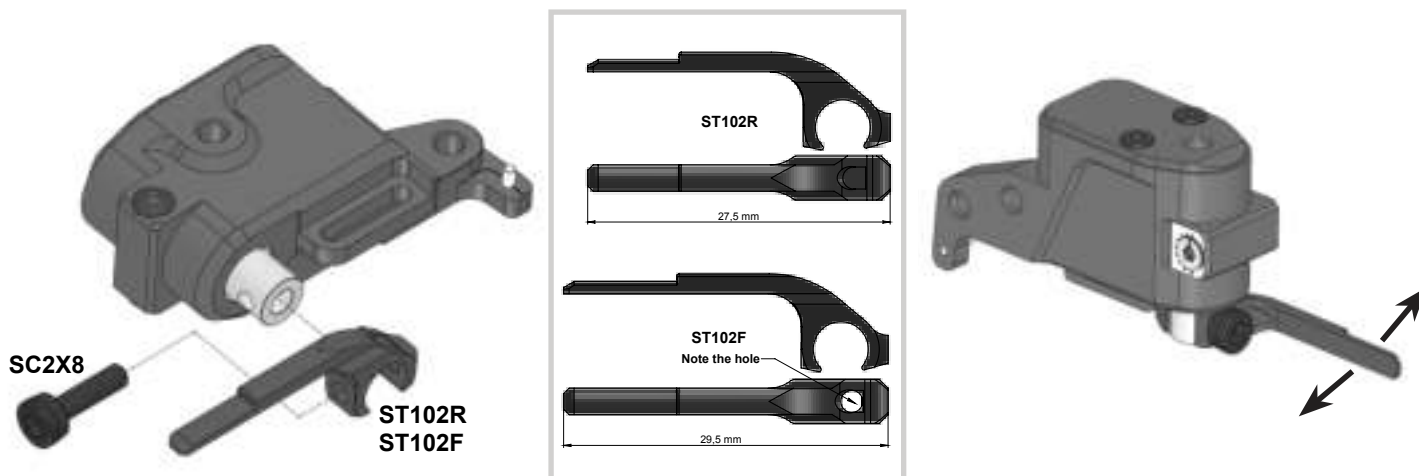

**Comment:** Note that dampers are used in the car in horizontal position. So the possible small air bubbles are located near to the top wall of the damper and don't affect on the rotor action. So these dampers are equally effective on track even with a bit of the air bubbles inside. You can feel the air bubbles only when you place dampers vertically and air bubbles can go through the rotor blade edge.

**#13** Install **AT119**, **SPR23**, **P46R**, **ST69-0** and note orientation of **SPR23** by the round end directed to the damper shaft.

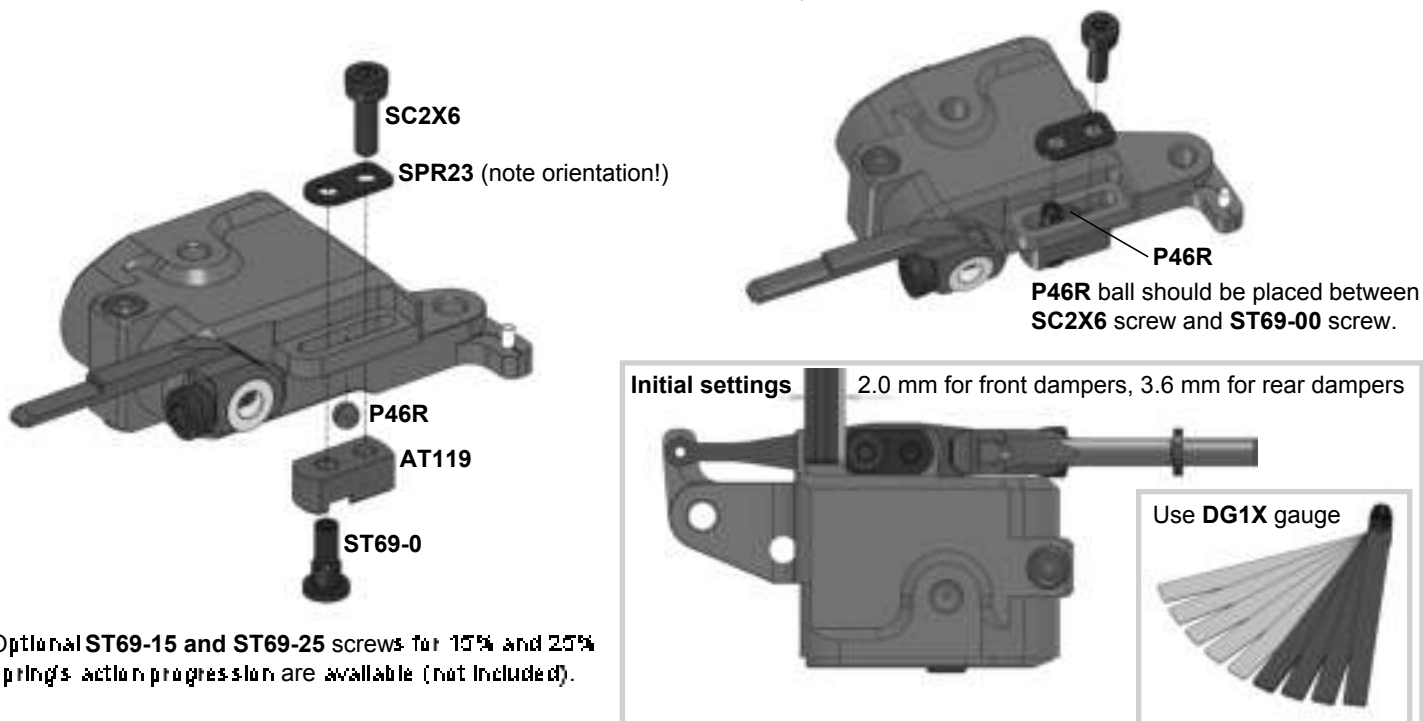

Optional **ST69-15** and **ST69-25** screws for 15% and 25% springs action progression are available (not included).

**#14** Install **SPR01** springs (for **A800R** kits) or **SPR01S** springs (for **A800RA** kits).

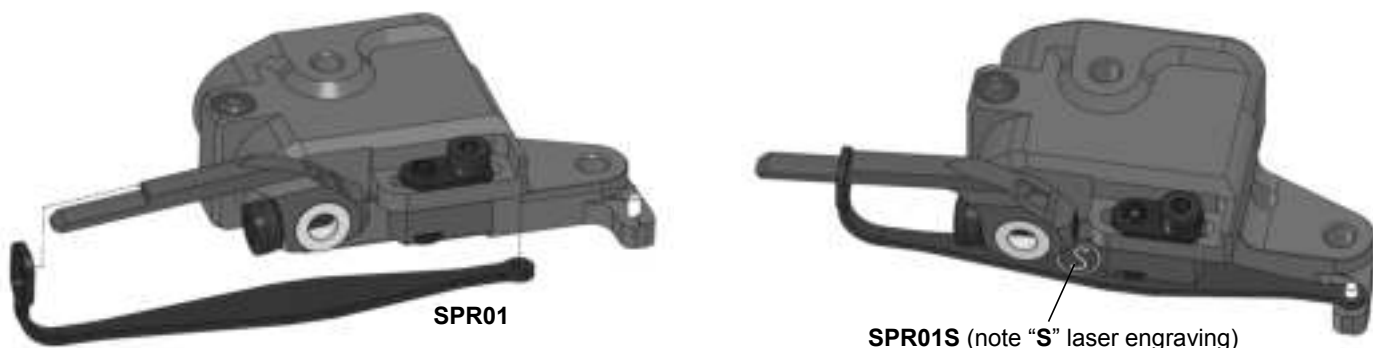

## STEP 2

**Note:** C01B-RC Carbon Lower Deck is used in A800R kit.  
C01B-RA Alloy Lower Deck is used in A800RA kit.

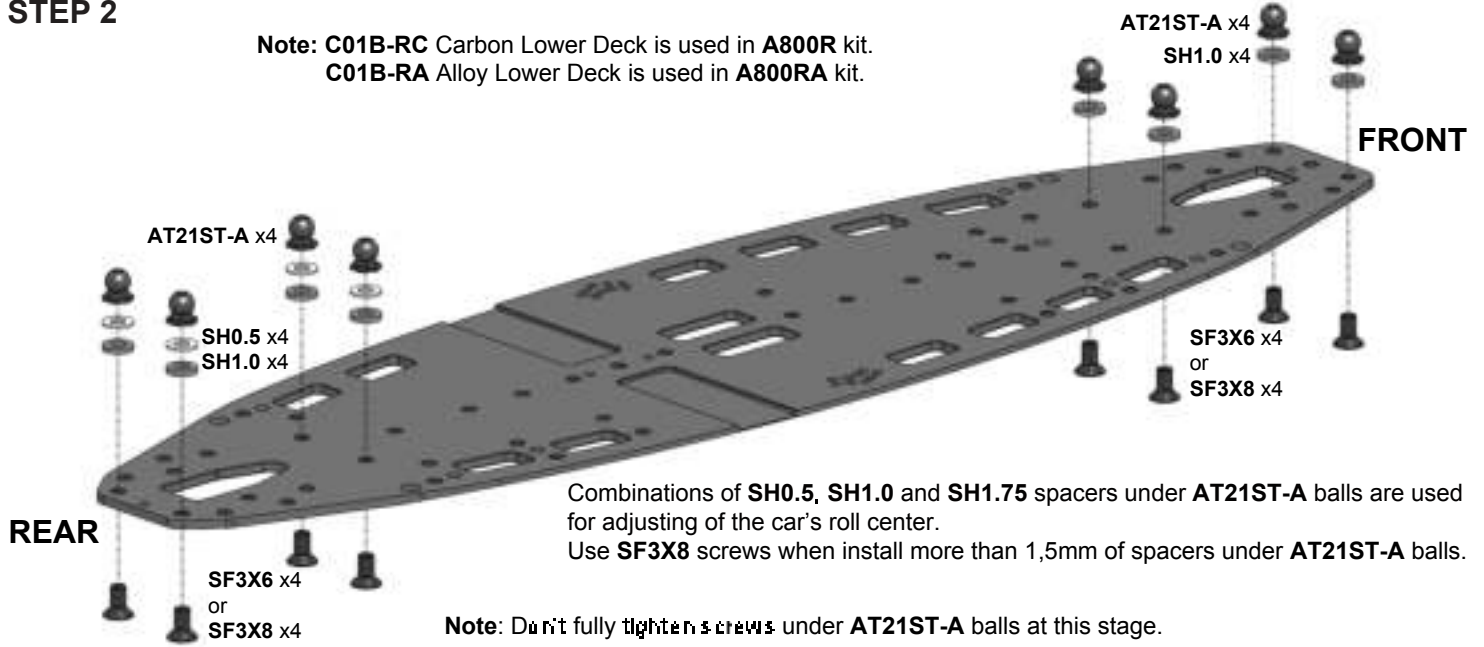

## STEP 3

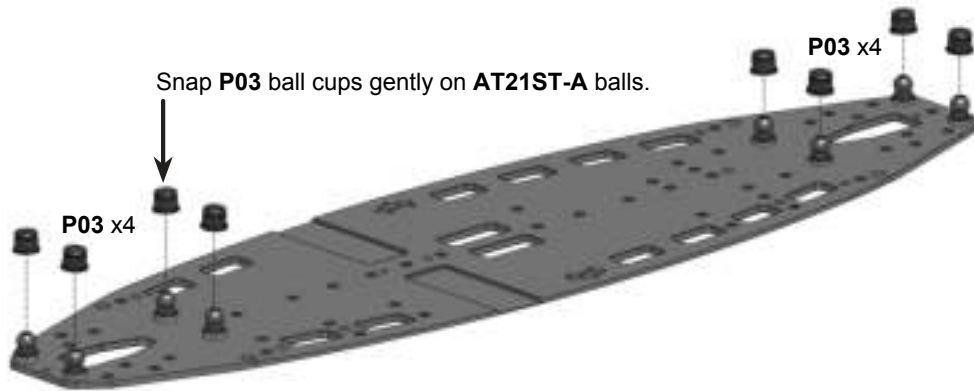

## STEP 4

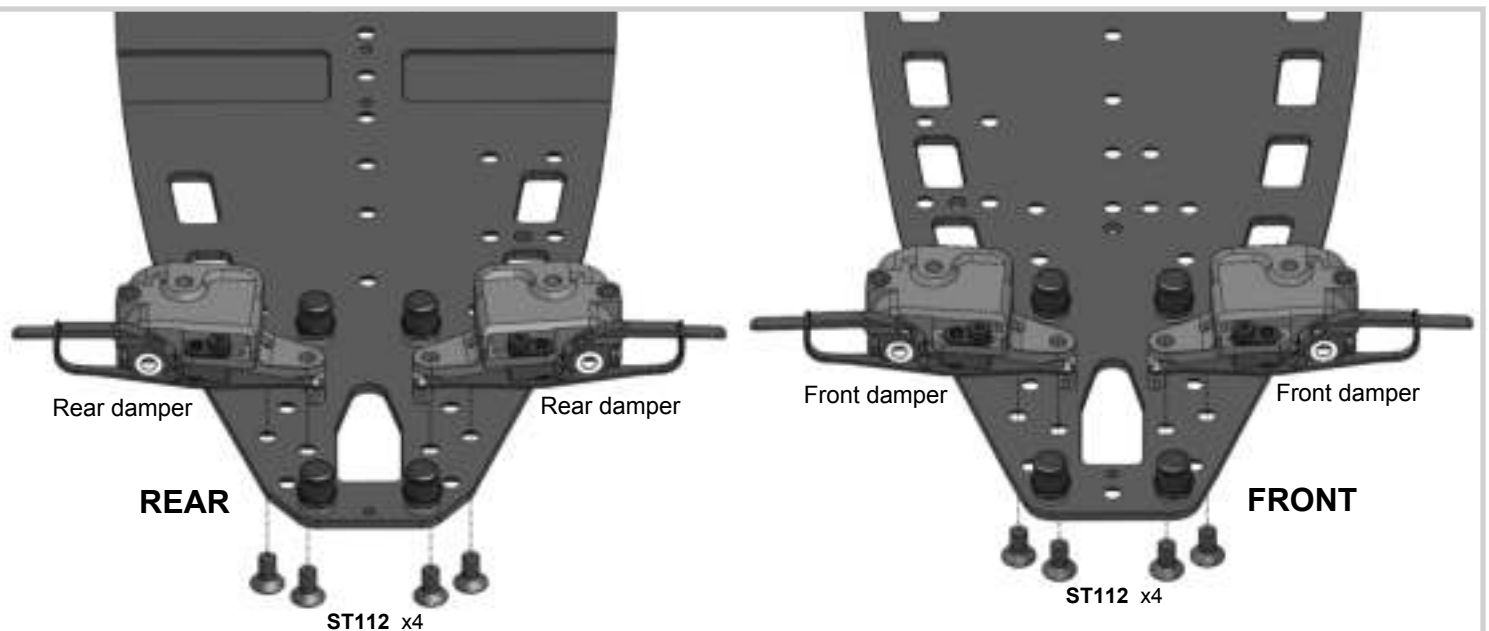

**Note:** Use ST112 centering screws for dampers mounting.



### STEP 5

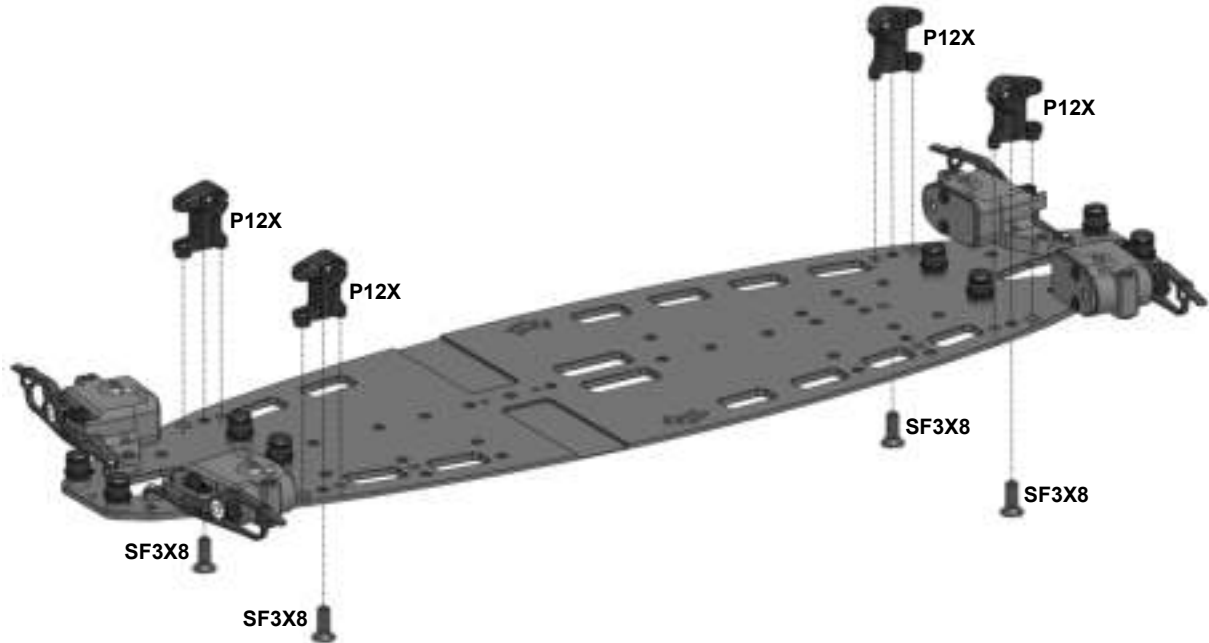

### STEP 6

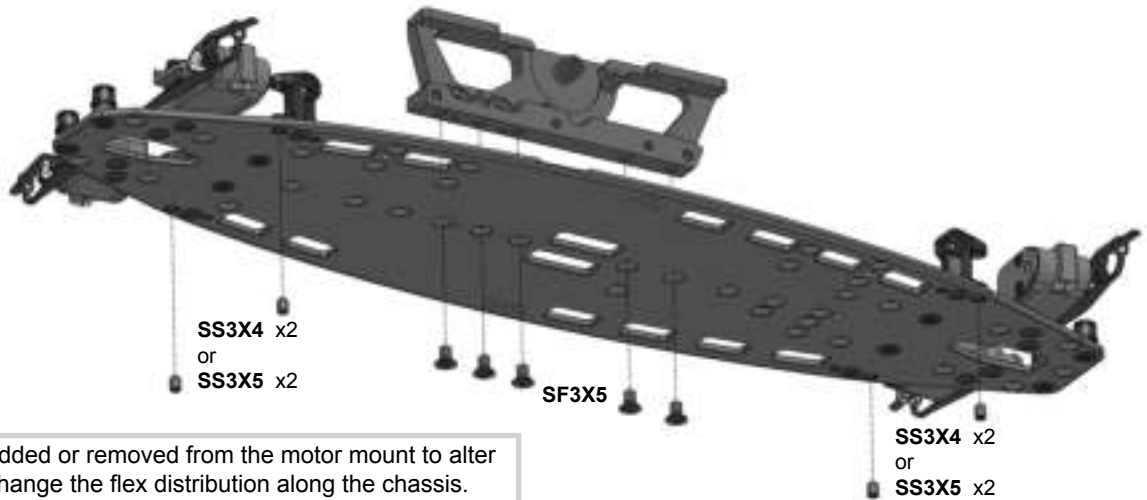

SF3X5 screws can be added or removed from the motor mount to alter overall flex, as well as change the flex distribution along the chassis.

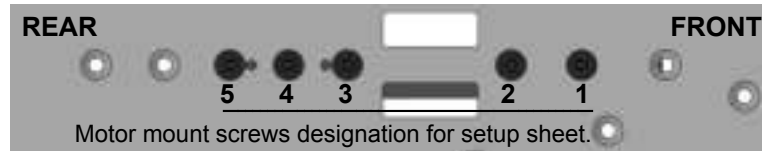

**Note:** SS3X5 set screws should be used if more than 2 mm spacers are used under AT21ST-A balls.

### STEP 7

Snap C204R and C204L lower arms on P03 cups. Note orientation of recesses on the arms!  
**Note:** C204R and C204L lower arms should swing down free under its weight.

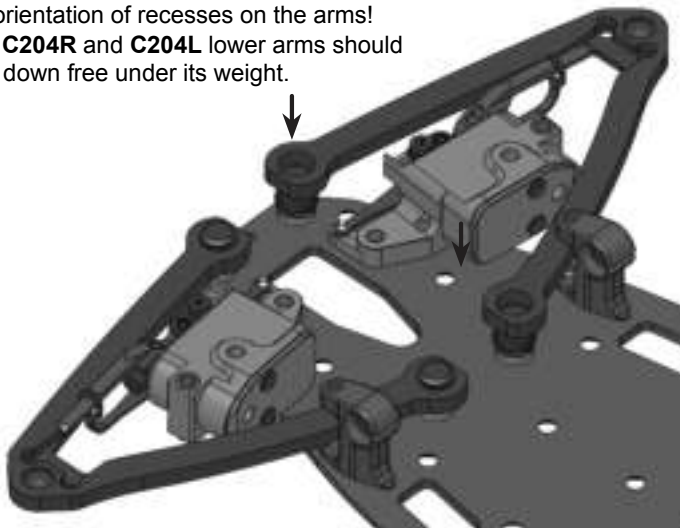

Crimp P03 cups with flat lips pliers if the lower arms movement is not free.



### STEP 8

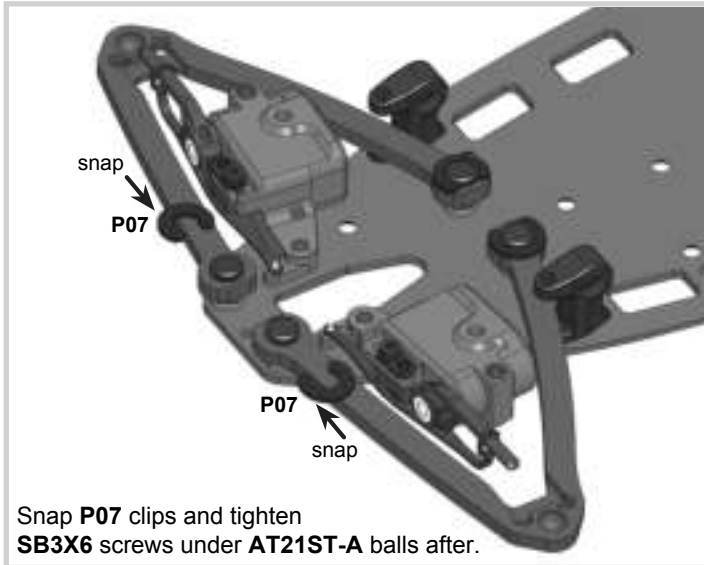

Optional **OR14V** rubber o-rings can be used instead of **P07** clips.

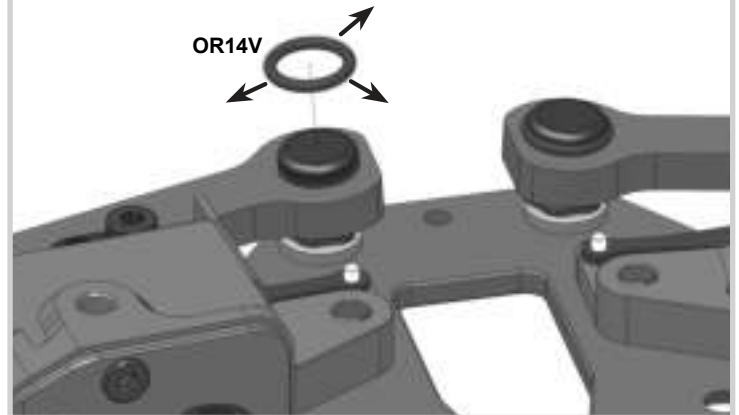

### STEP 9

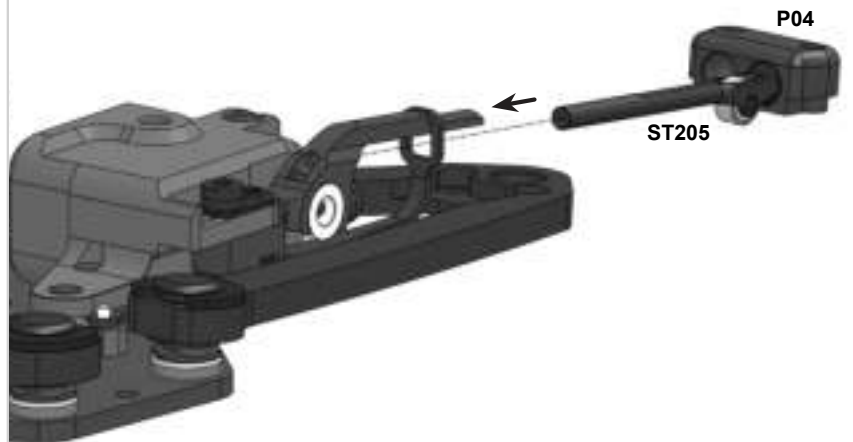
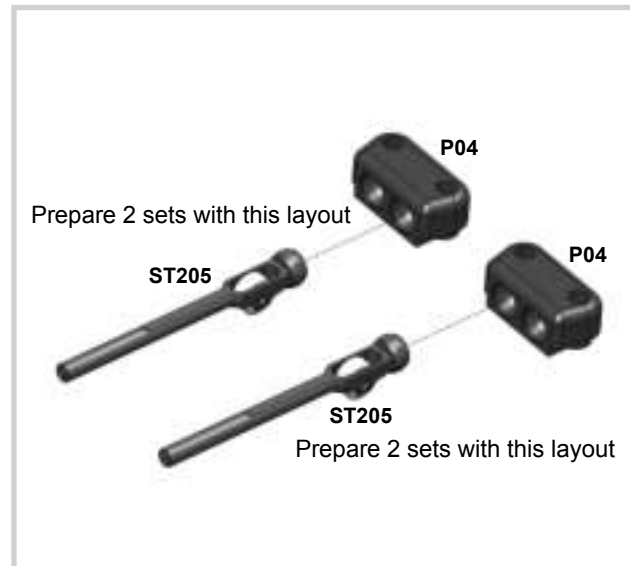

### STEP 10

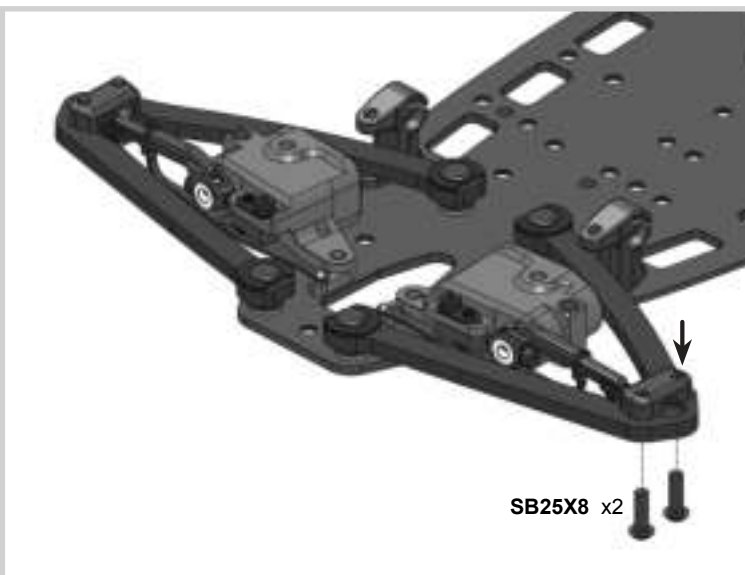

## STEP 11

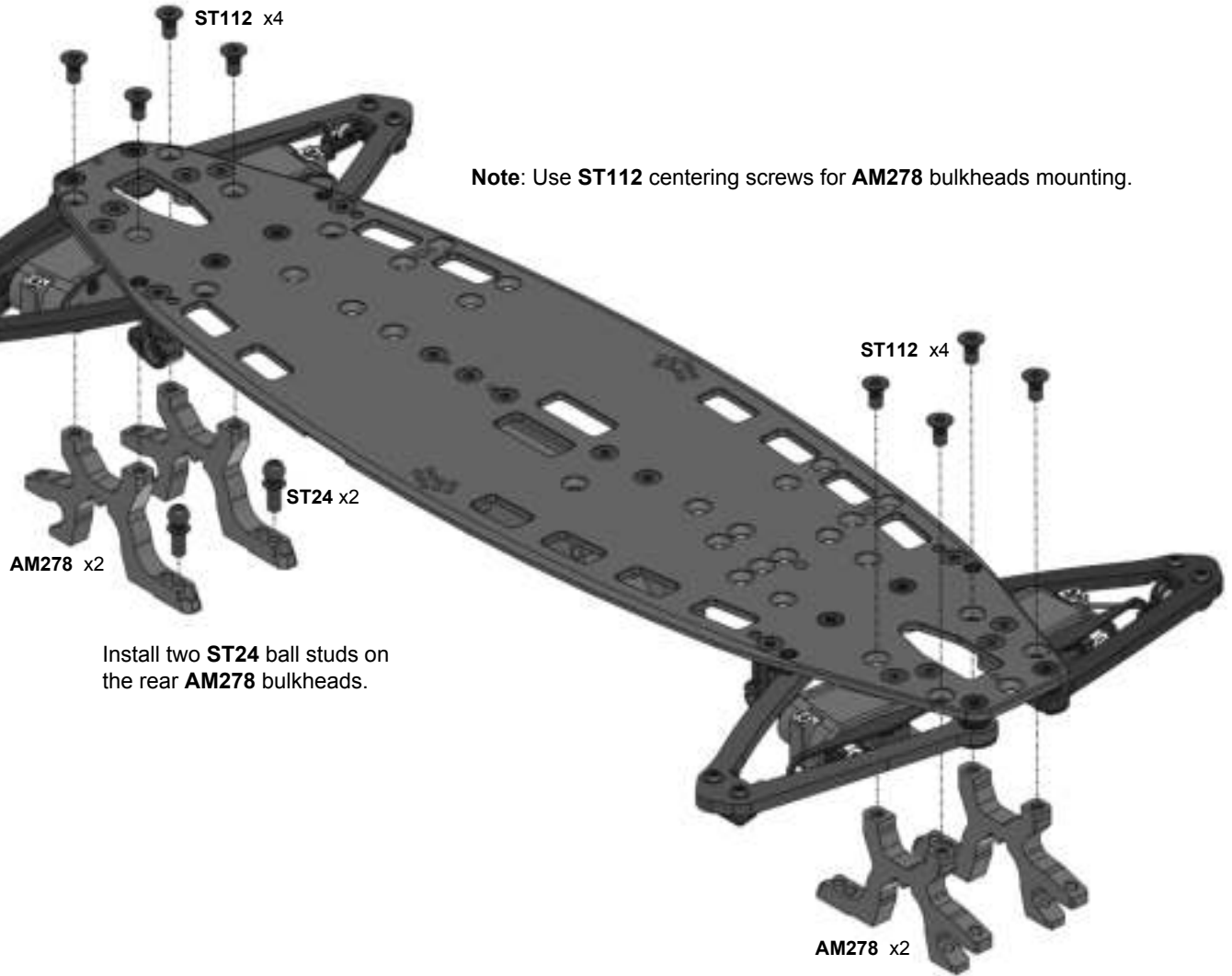

## STEP 12

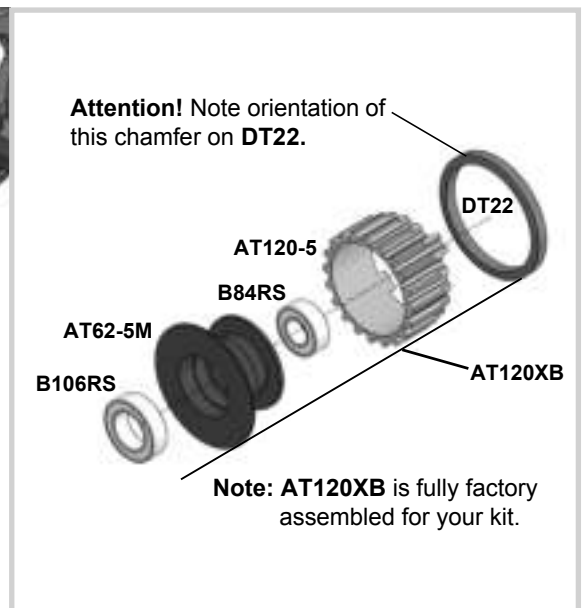
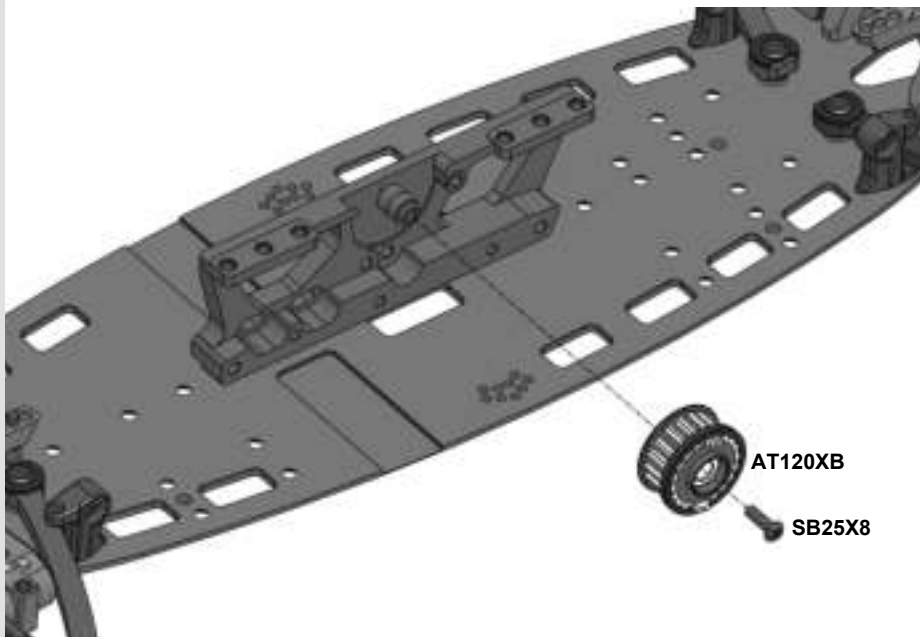

### STEP 13

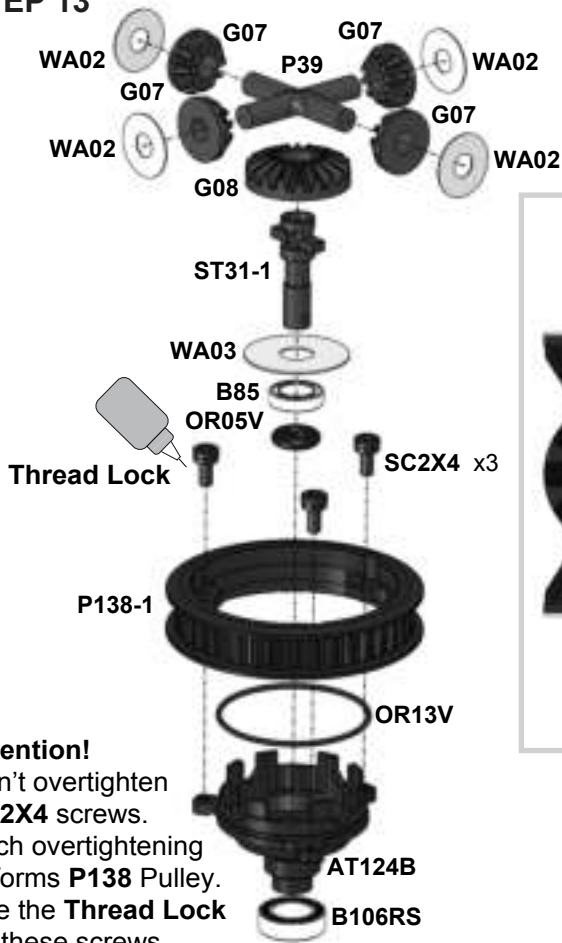

**Attention!**  
 Don't overtighten **SC2X4** screws.  
 Such overtightening deforms **P138** Pulley.  
 Use the **Thread Lock** for these screws.

### STEP 14

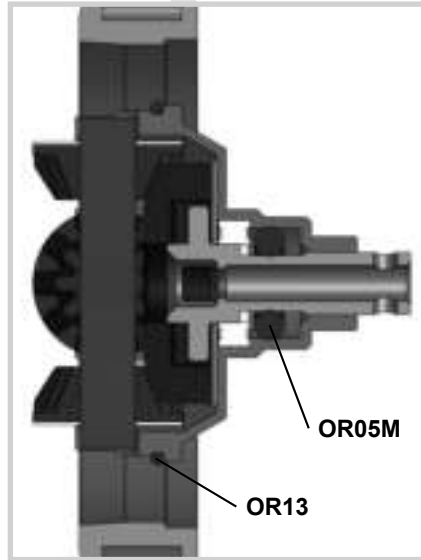

**TIP / Recommendation to use**  
 MAX-01-003 - MXLR O-Ring grease (for OR05V)  
 MAX-02-002 - MXLR Awesomatix TC Multi Tool

### STEP 15

Fill with desirable silicone oil (not included).  
 Screw **AT123B** case with 10mm wrench slowly.  
 The excessive oil will go out through the **ST31-1** axial hole.

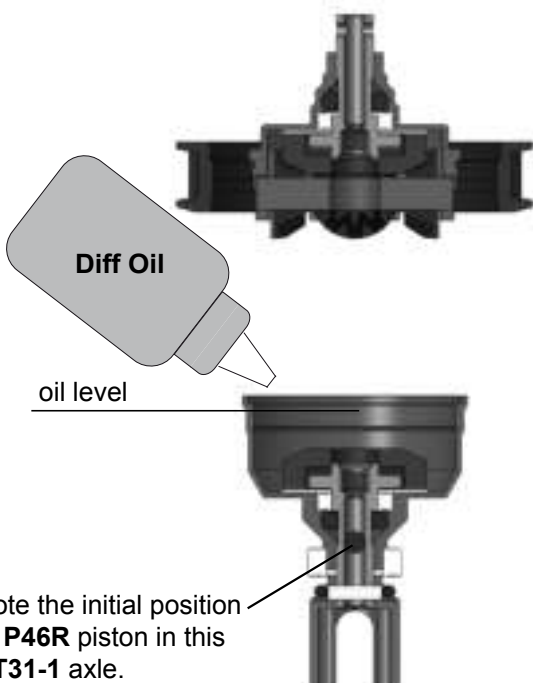

Note the initial position of **P46R** piston in this **ST31-1** axle.

### STEP 16

**TIP / Recommendation to use**  
 MAX-01-001 - MXLR Ball Bearing oil

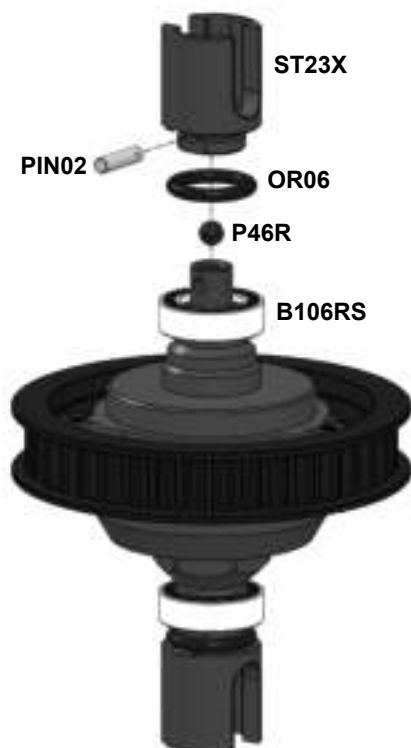

## STEP 17

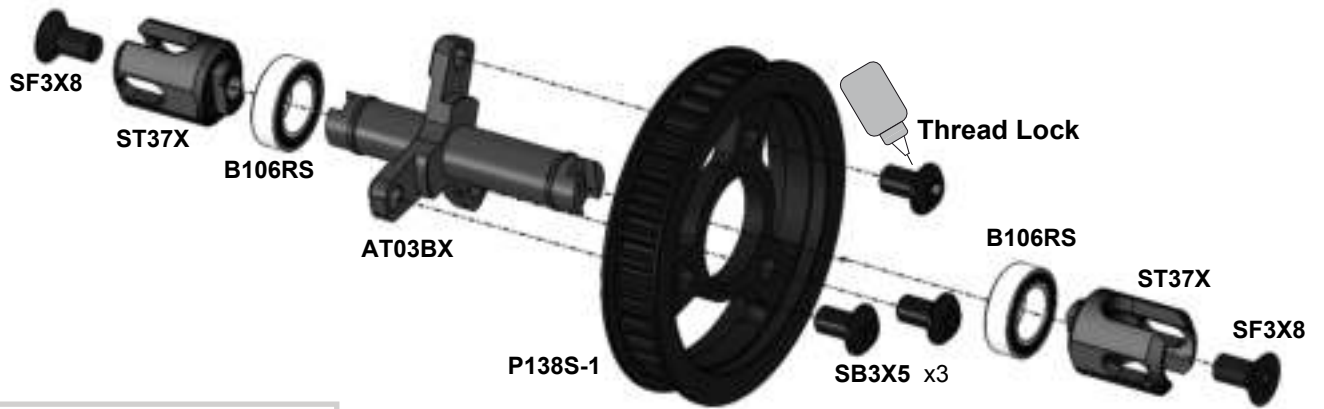

**TIP / Recommendation to use**  
MAX-01-001 - MXLR Ball Bearing oil

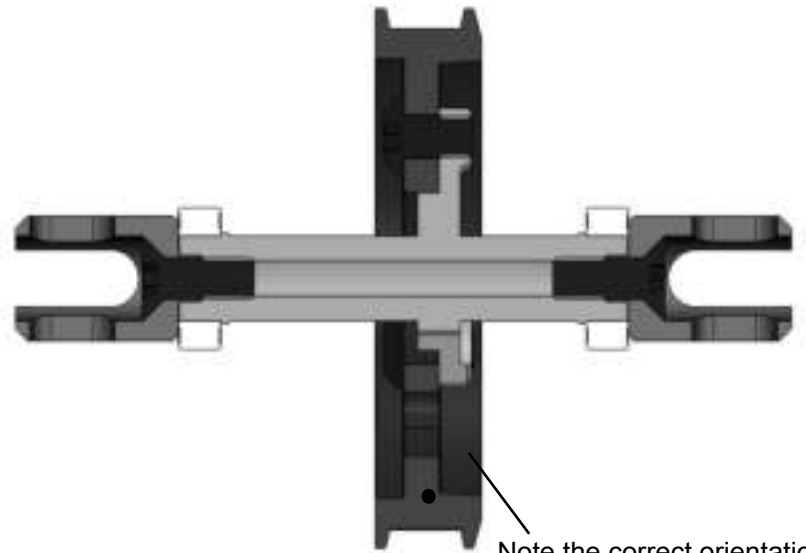

**Attention!**

Don't overtighten **SC3X5** screws.  
Such overtightening deforms **P138S** Pulley.  
Use the **Thread Lock** for these screws.

Note the correct orientation  
of **AT03BX** Axle regarding  
to **P138S** Pulley.

## STEP 18



STEP 19

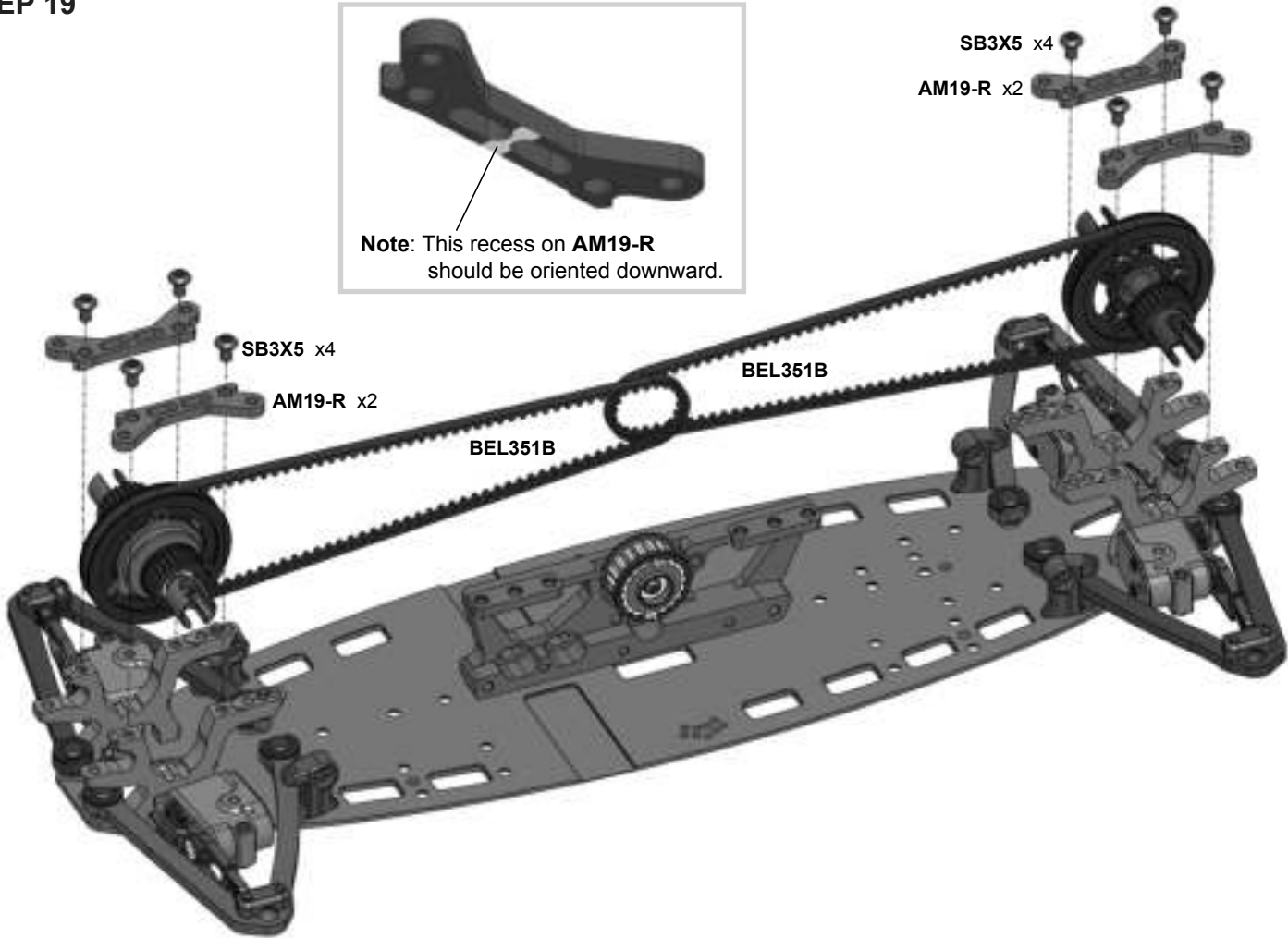
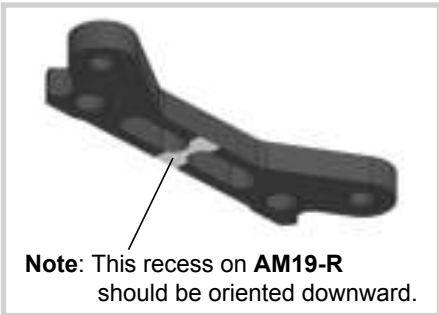

Note this correct layout of of belts, diff and spool!

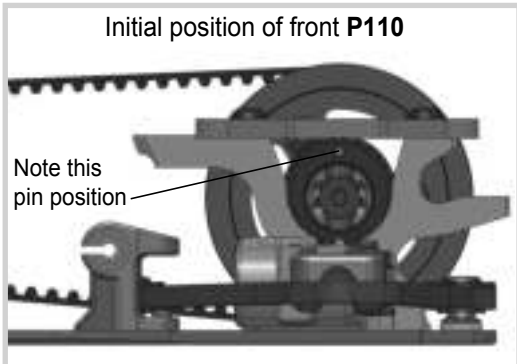
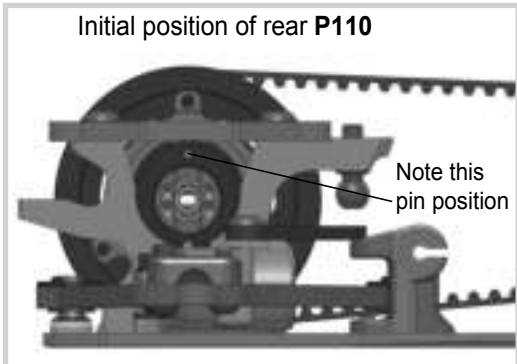
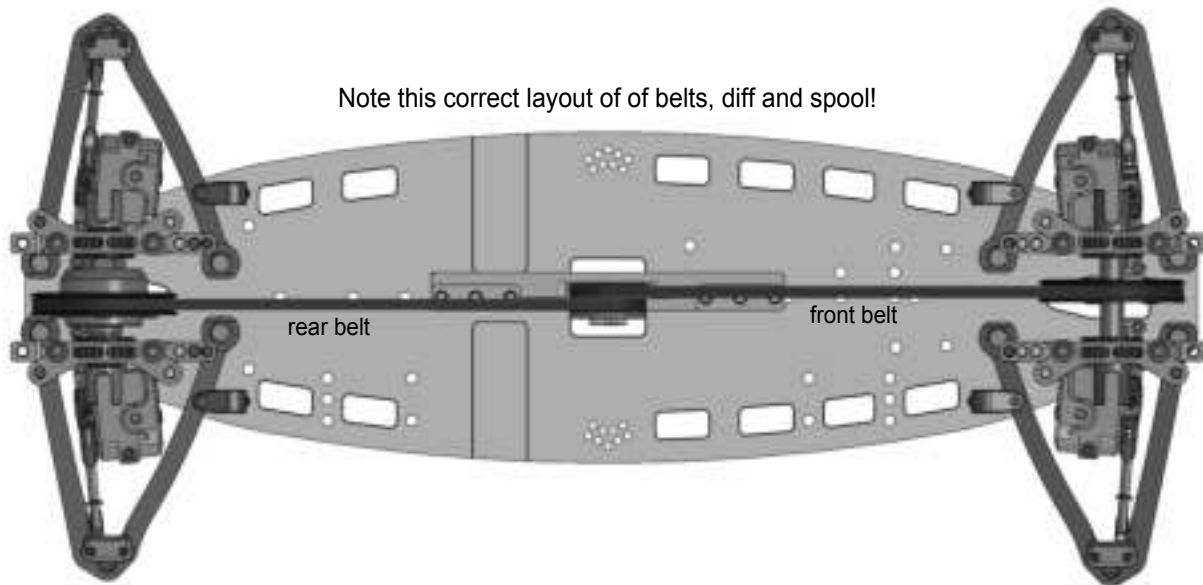

### STEP 20

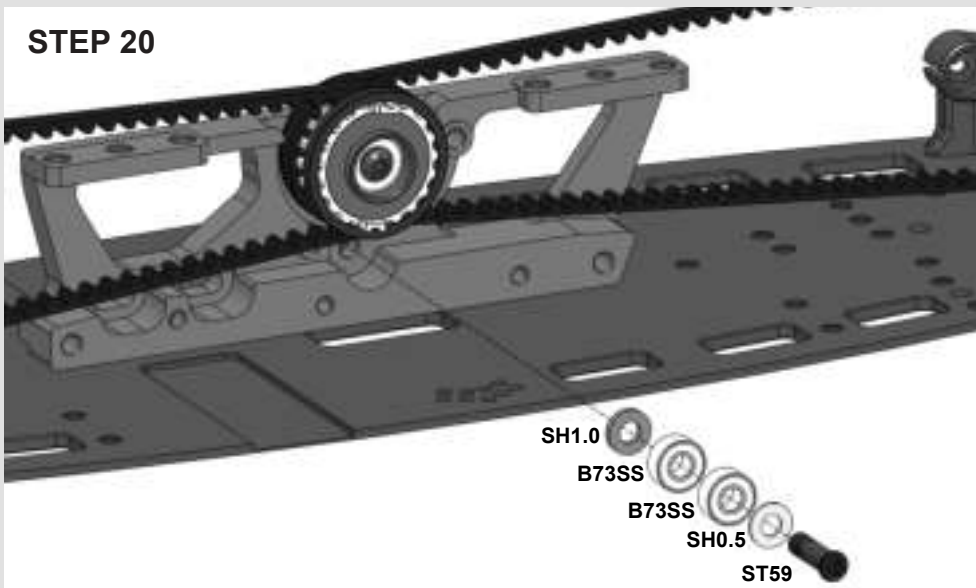

ST59



### STEP 21

**Note:** Don't tighten **SS3X3** set screws on this stage.

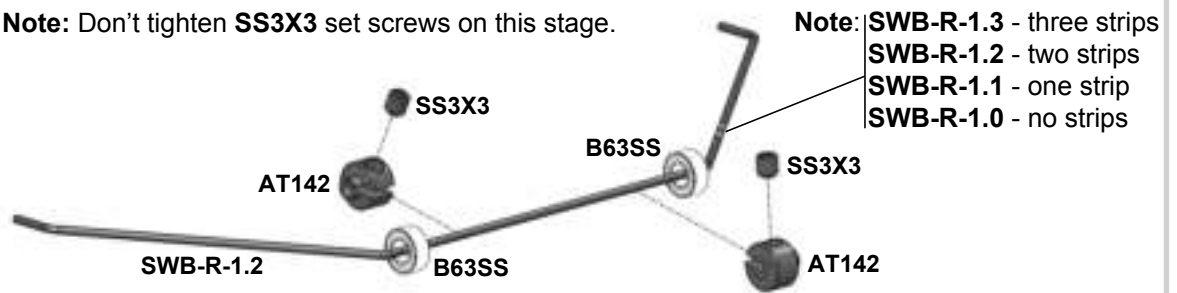

Install rear and front sway bars into **P12X**.  
Adjust **AT142** stoppers disposal to reach the centered position of sway bars and tighten **SS3X3** set screws after that.

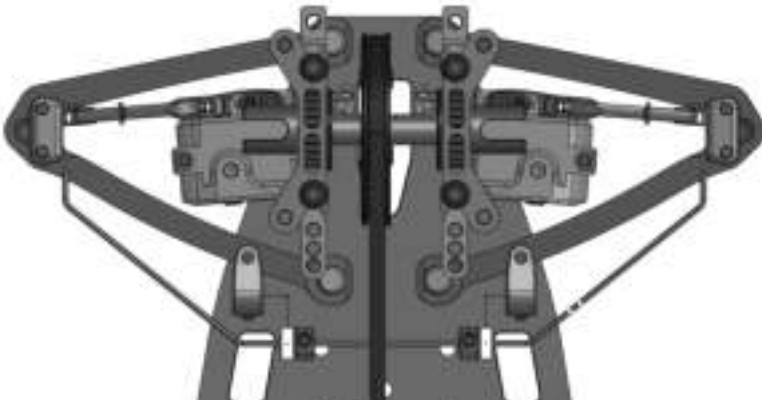

**Attention!**

The deflected tips of sway bar should be directed downwards.



Cut off this leg of **P12X** when using more than 3 mm spacers under **AT21ST-A** balls.



### STEP 22



Use bigger hole for **SWB-R-1.2** and **SWB-R-1.3** sway bars.

Use smaller hole for **SWB-R-1.0** and **SWB-R-1.1** sway bars.

P05

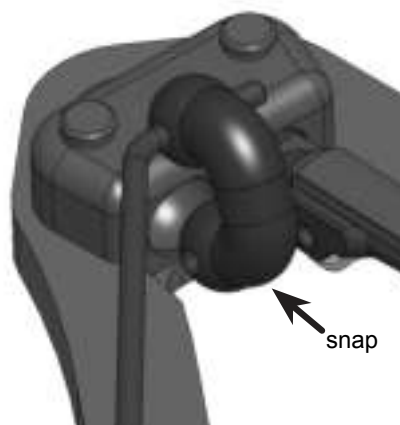

snap

Install **P05** on all four suspension arms.



### STEP 23

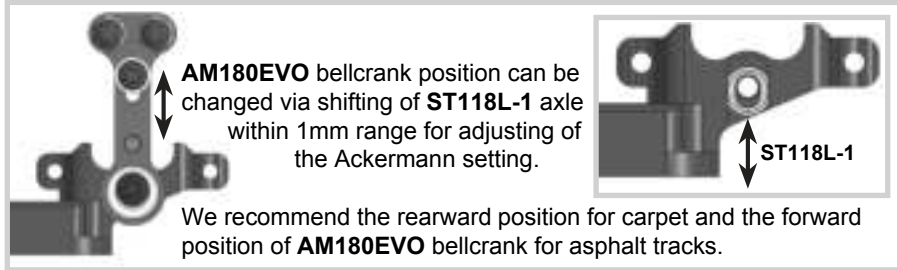
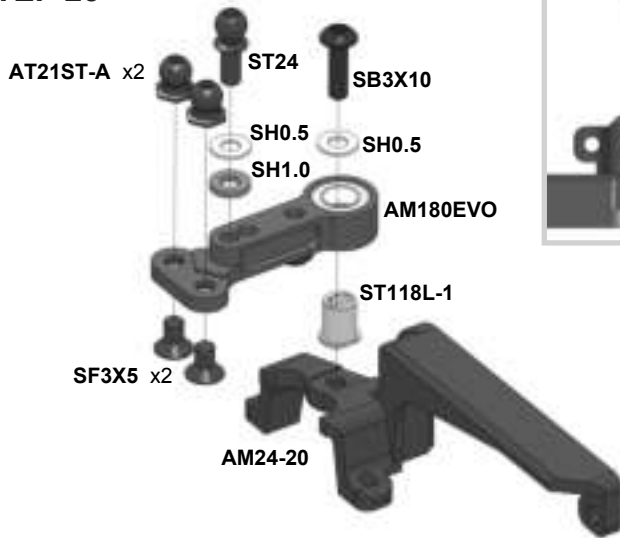

Use **SB3X5AL** screw as a steering limiter (usually on carpet tracks).



### STEP 24

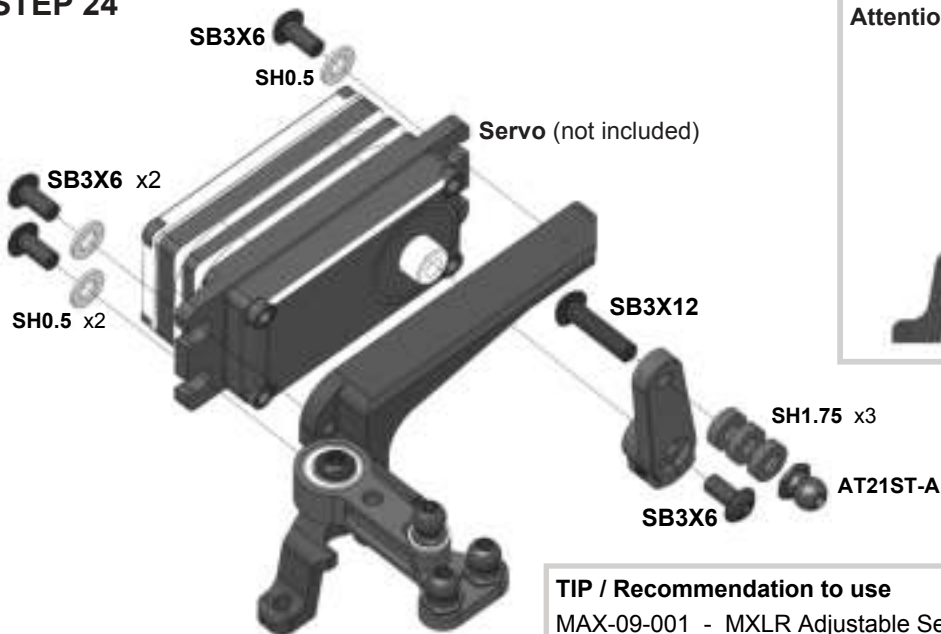

**Attention!** Servo horn neutral position.

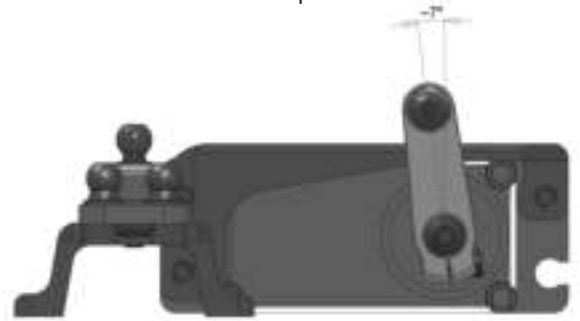

**Servo horn (not included)**

**Note:**  
Recommended length of the servo horn 16,5-17,5 mm.



**TIP / Recommendation to use**

- MAX-09-001 - MXLR Adjustable Servo Arm 23T
- MAX-09-002 - MXLR Adjustable Servo Arm 25T

### STEP 25

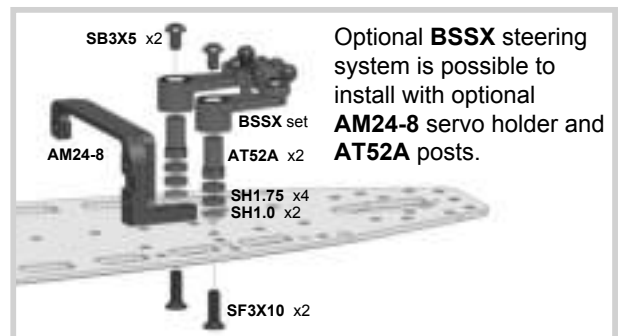
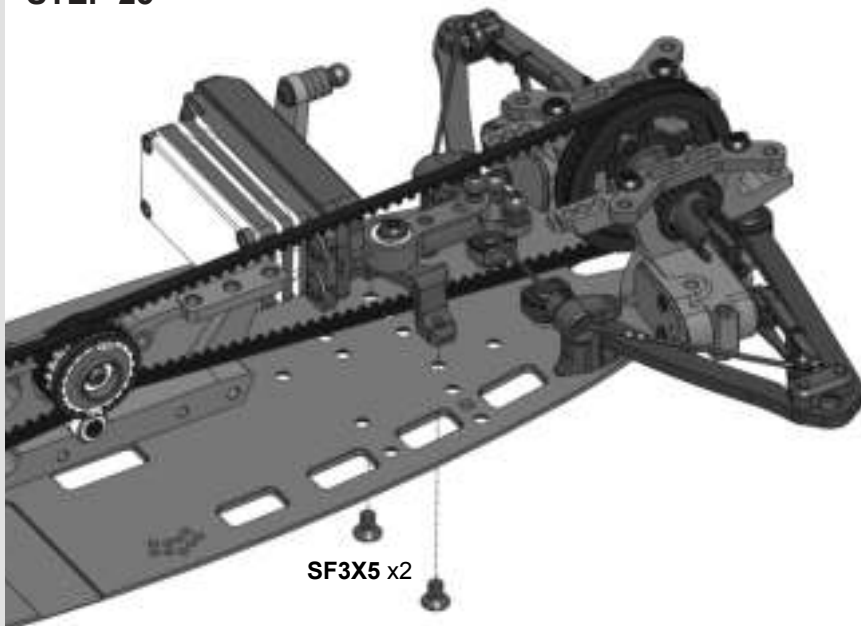

Optional **BSSX** steering system is possible to install with optional **AM24-8** servo holder and **AT52A** posts.

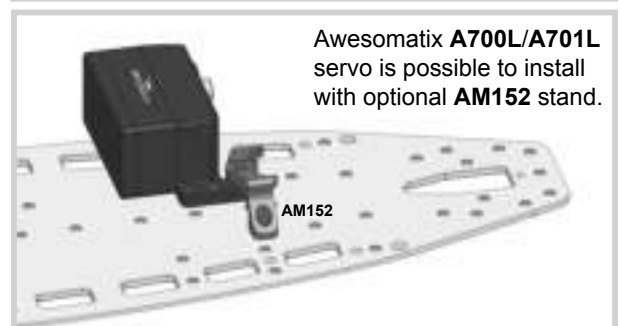

Awesomatix **A700L/A701L** servo is possible to install with optional **AM152** stand.



### STEP 26

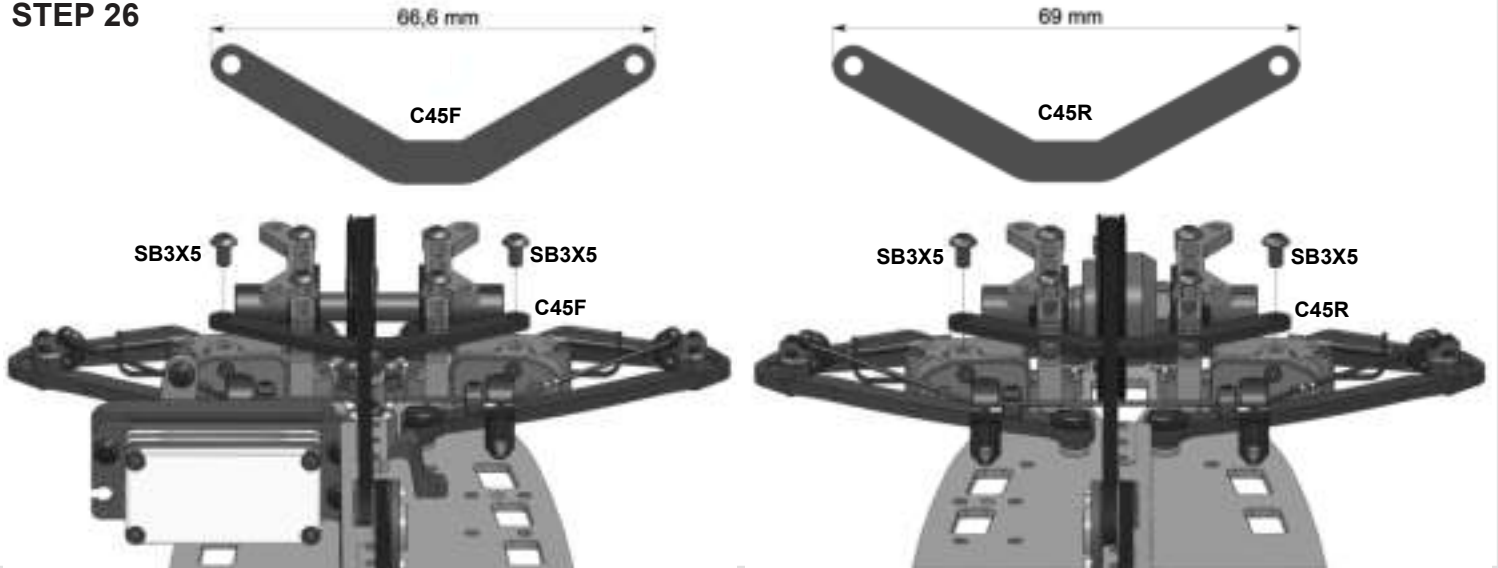

### STEP 27

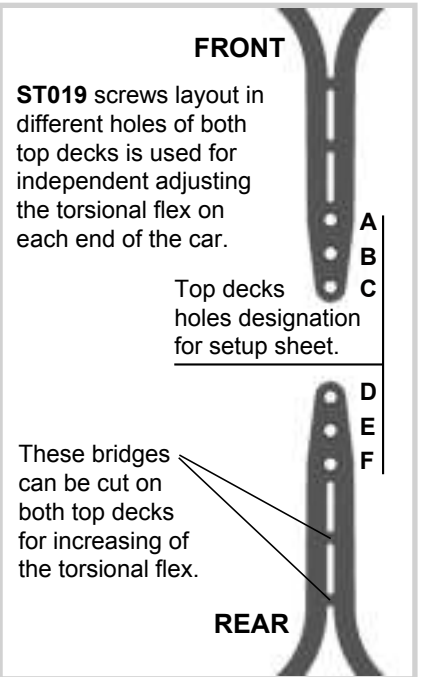
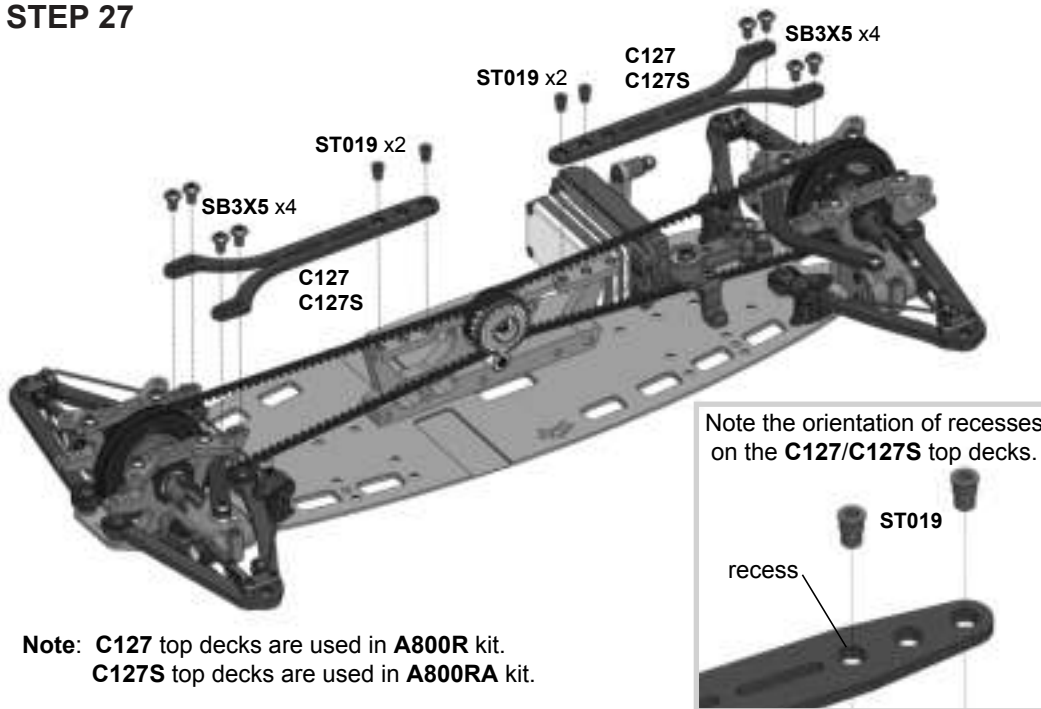

### STEP 28

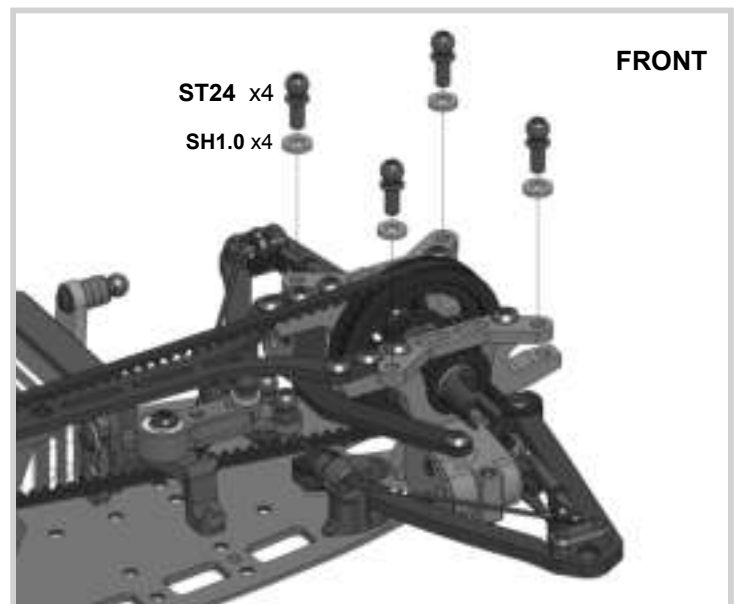
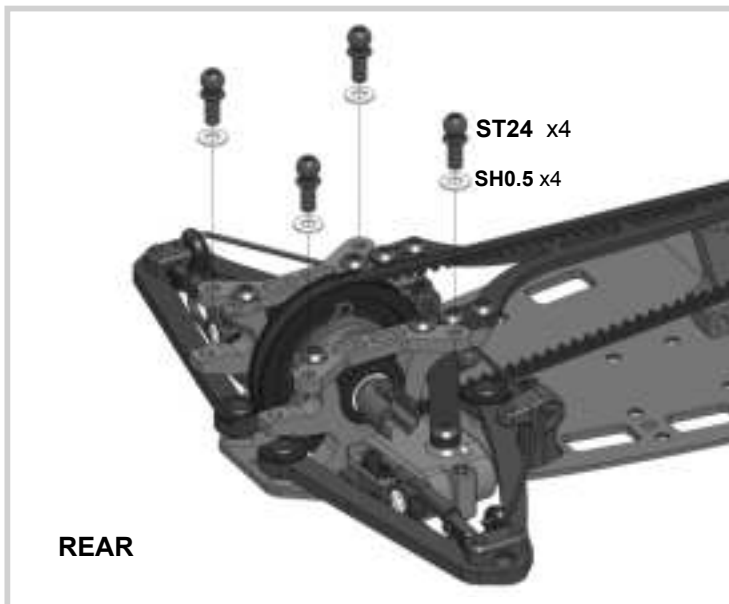

**STEP 29**

Front left steering knuckle

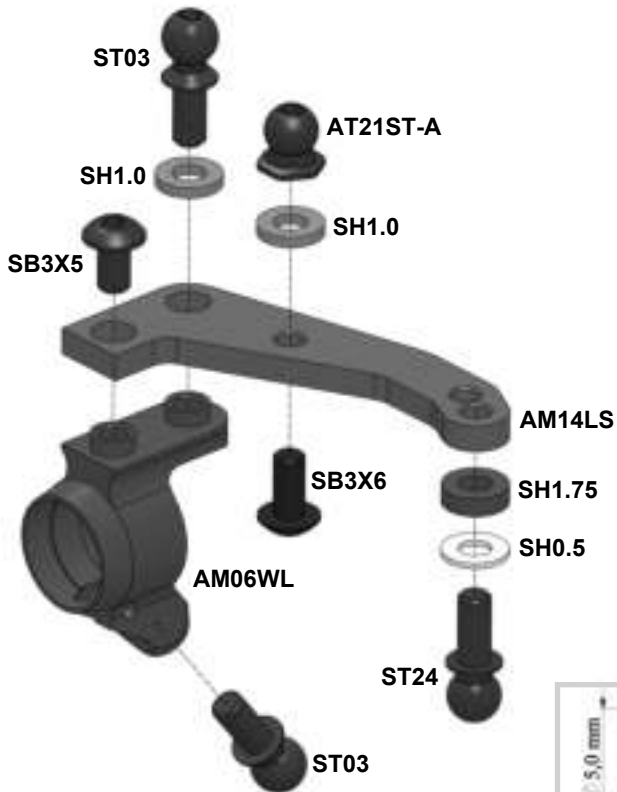

Rear right steering knuckle

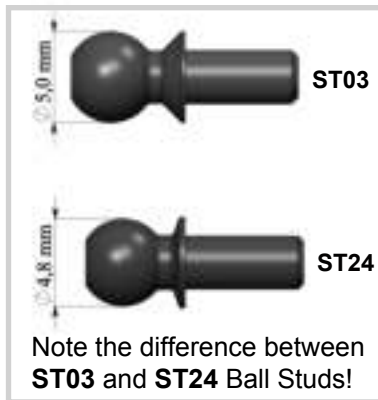
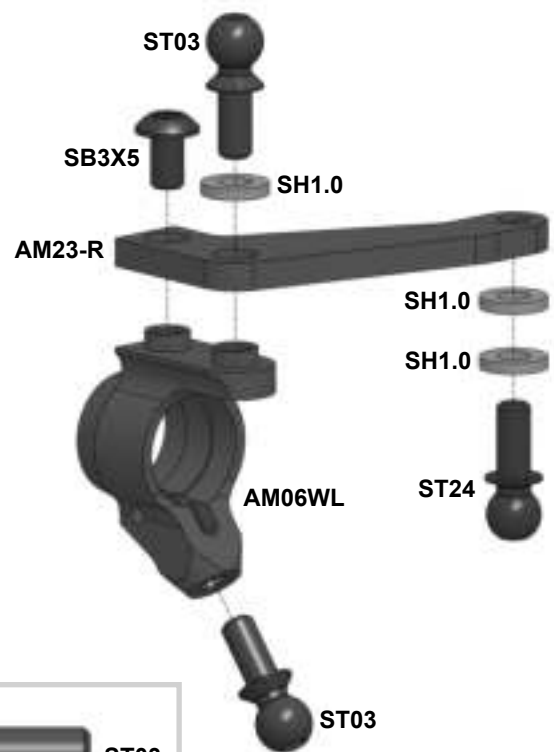

**Note:** Other combinations of **SH0.5**, **SH1.0** and **SH1.75** spacers can be installed under **ST03** and **ST24** ball studs to set-up the car for different track condition.

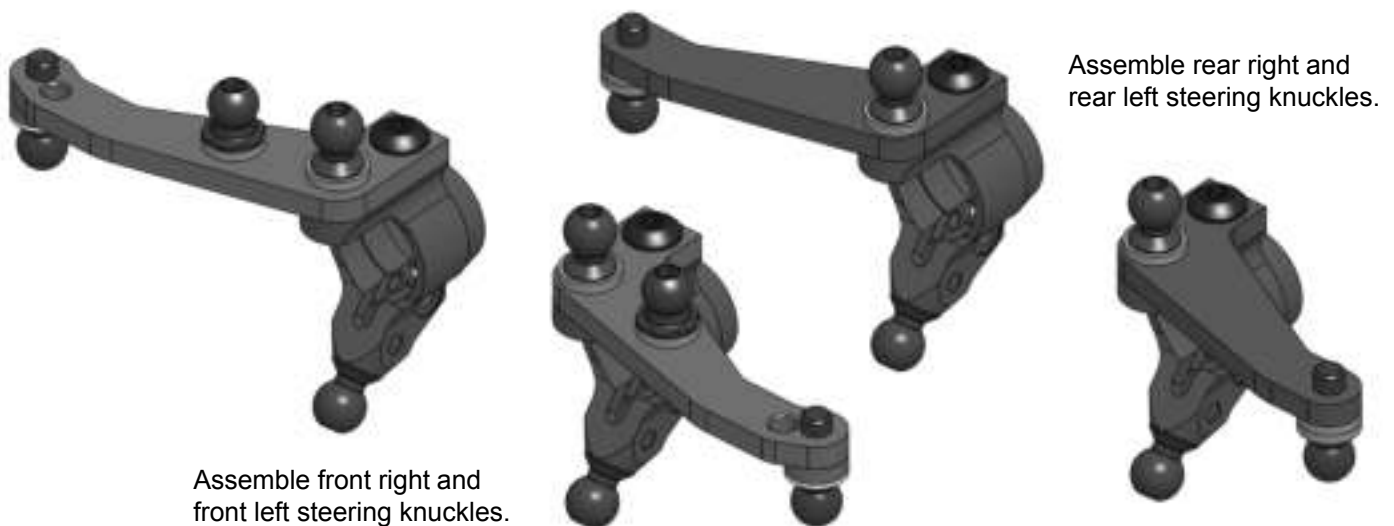

# STEP 30

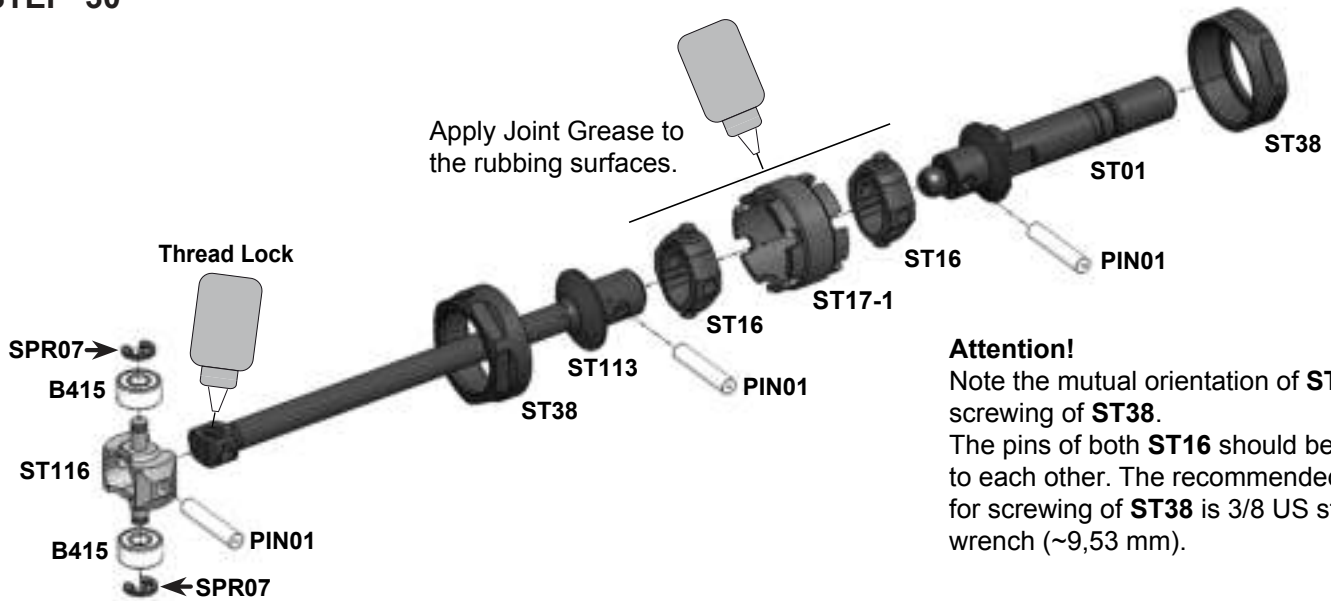

**Attention!**  
 Note the mutual orientation of **ST16** at screwing of **ST38**.  
 The pins of both **ST16** should be parallel to each other. The recommended wrench for screwing of **ST38** is 3/8 US standard wrench (~9,53 mm).

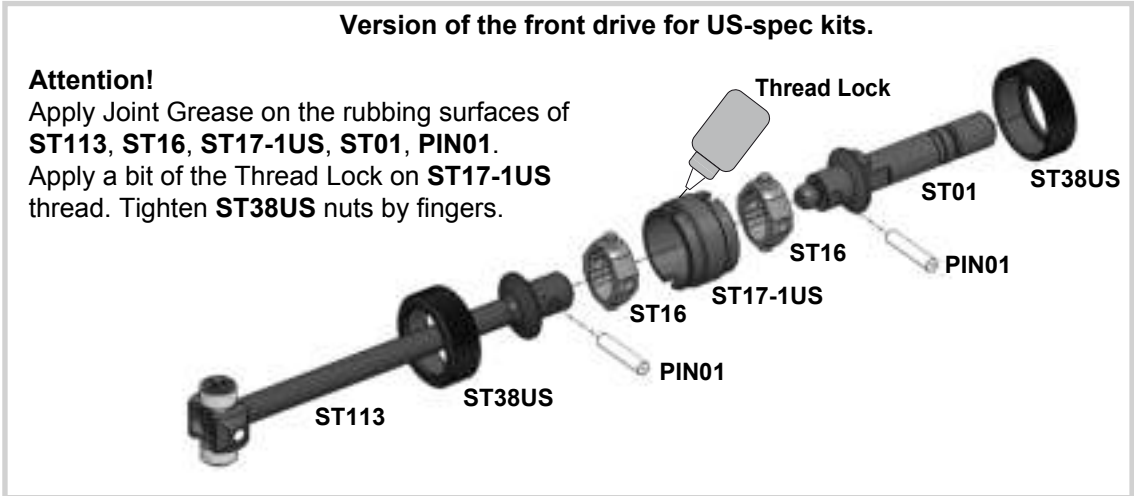

**TIP / Recommendation to use**  
 MAX-01-002 - MXLR Driveshaft & Gears oil  
 MAX-02-002 - MXLR Awesomatix TC Multi Tool



# STEP 31

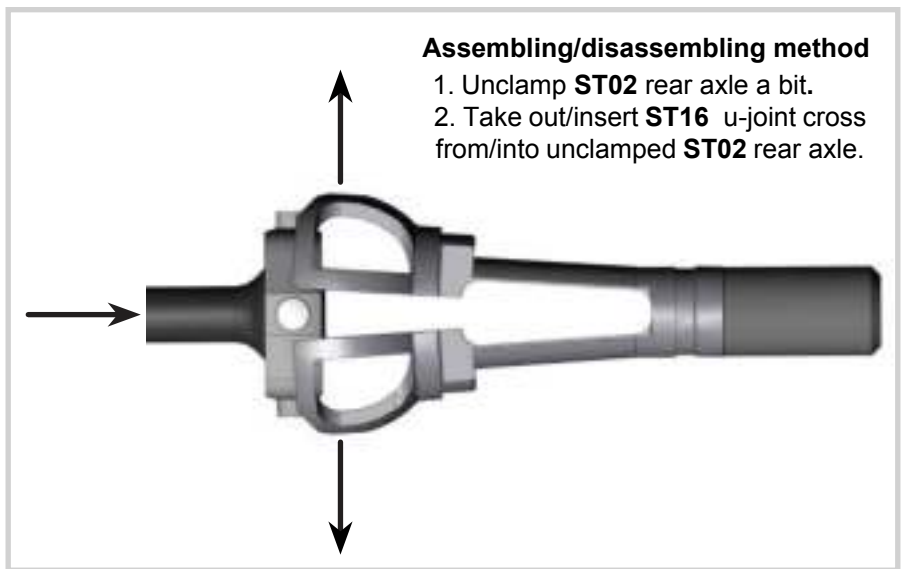
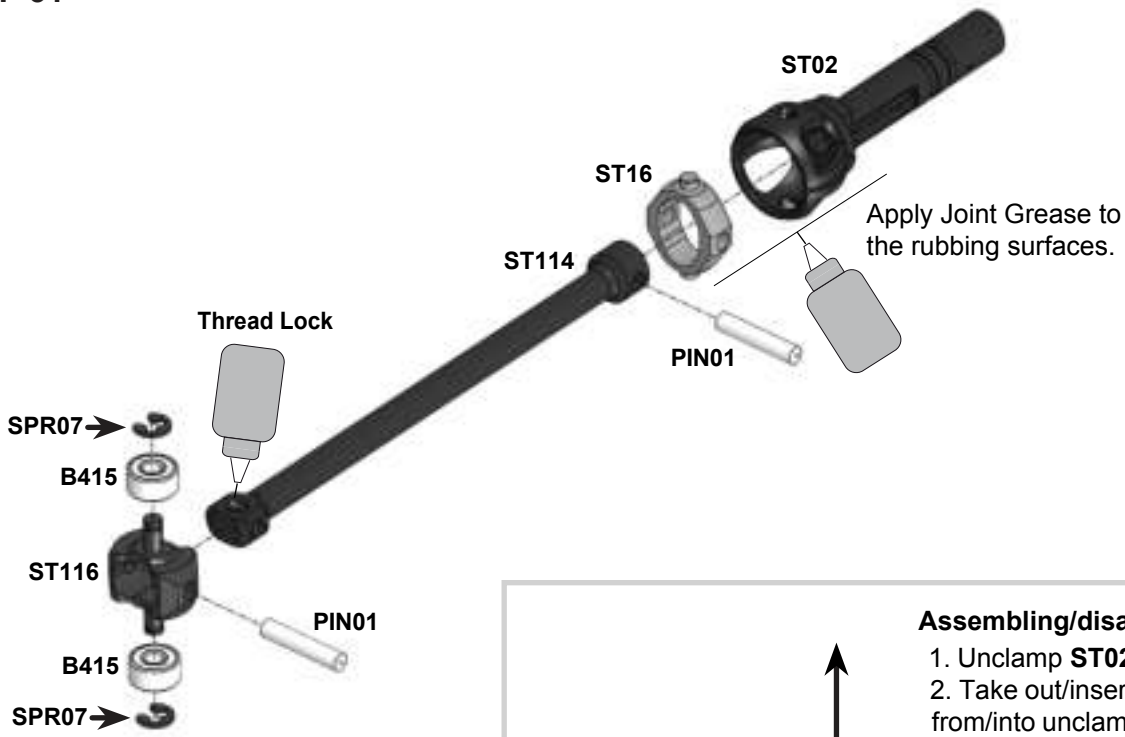

**Tip:**  
Use a 2.5mm flat screwdriver to unclamp **ST02** rear axle.



Prepare two rear drives.



**STEP 32**

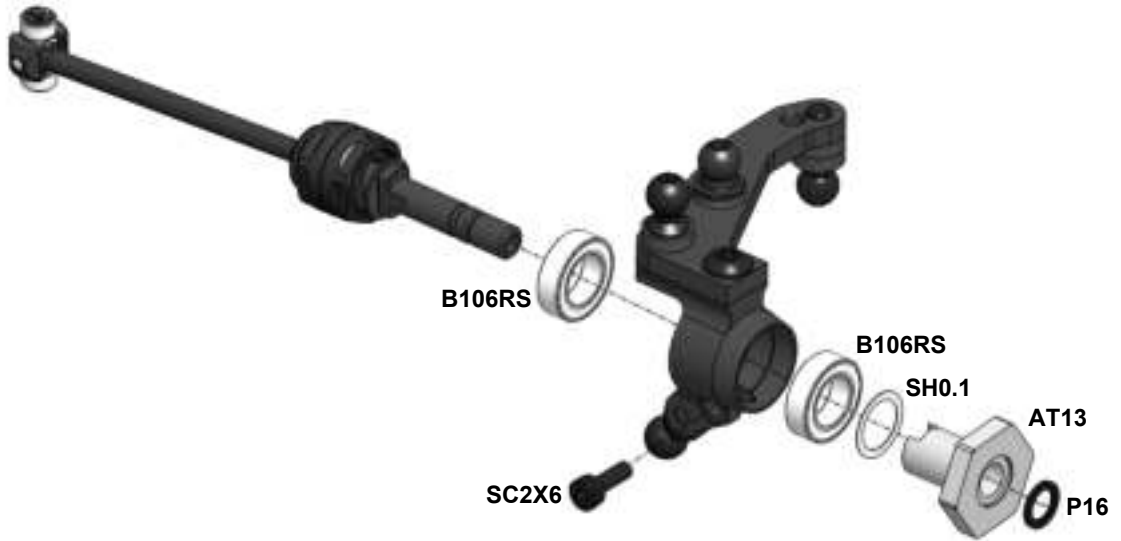

**Note:** We recommend to install **SC2X6** screws only at high traction conditions.

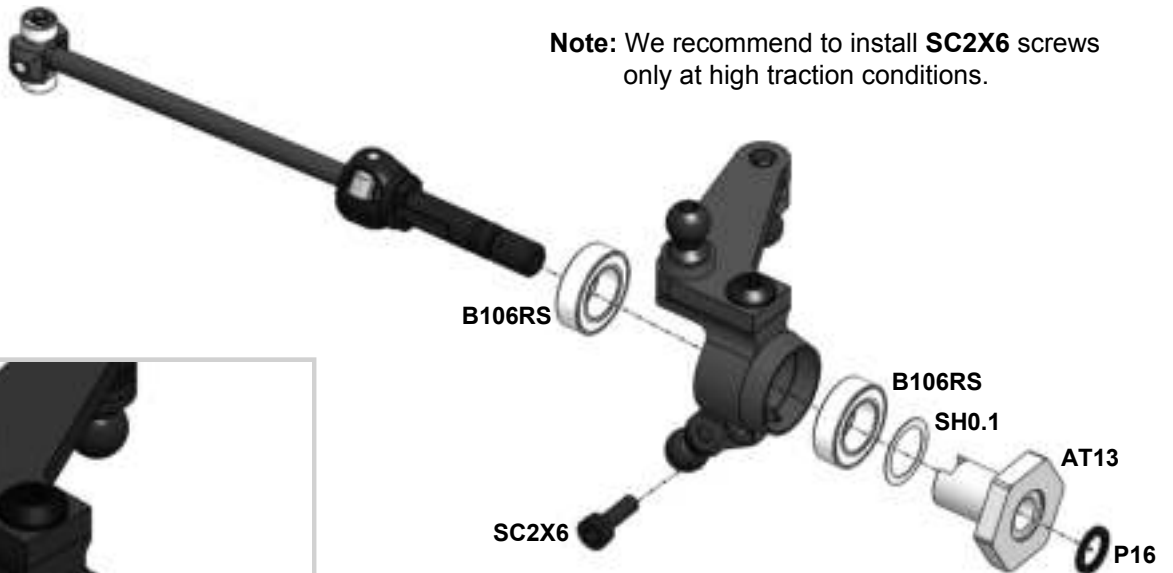

**Note:** Rear universal joints may be a bit tight at this stage. But don't worry as the rear universal joint take its true position after the wheels are mounted.

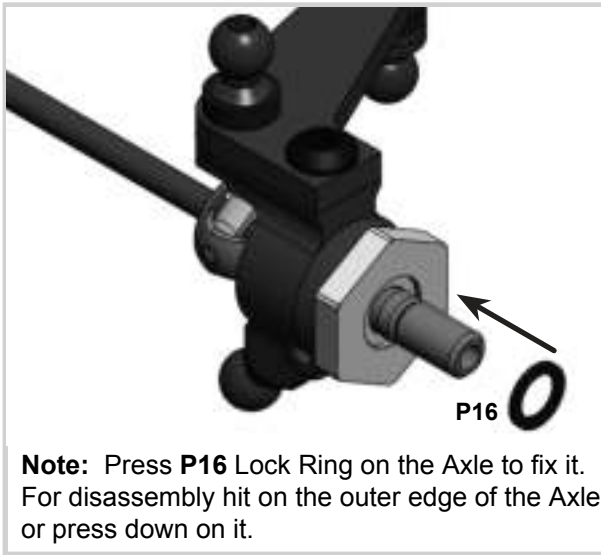

**Note:** Press **P16** Lock Ring on the Axle to fix it. For disassembly hit on the outer edge of the Axle or press down on it.

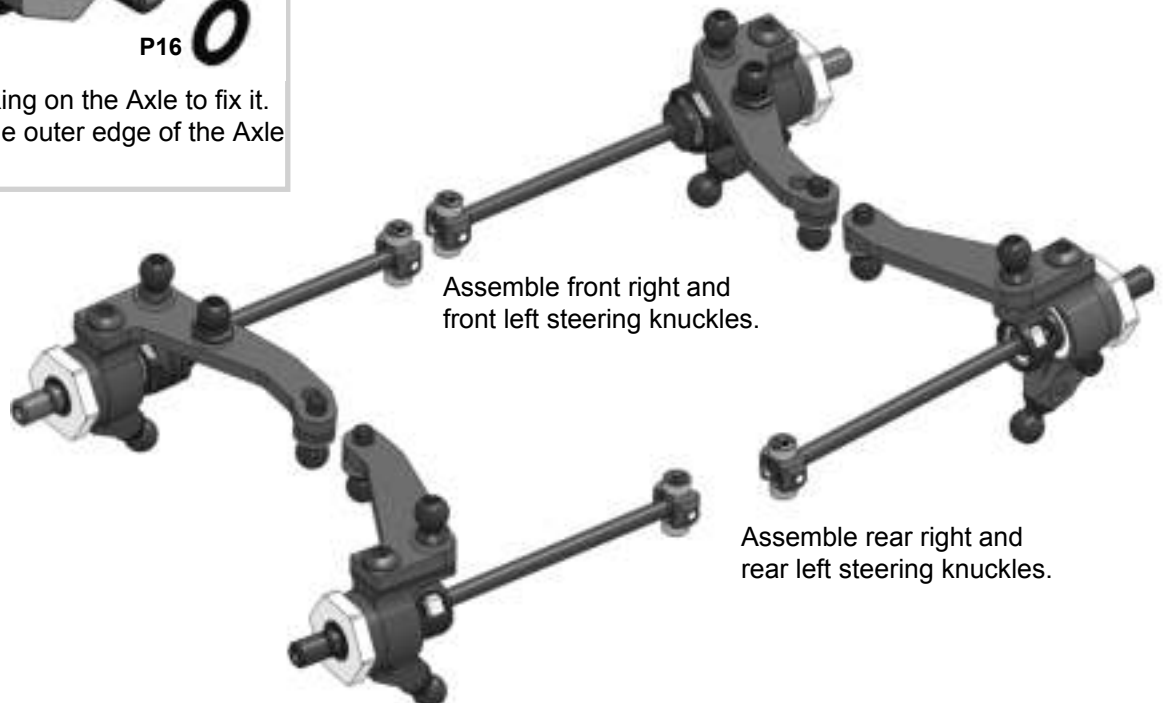

### STEP 33



**Notes:** The given rods and arms sizes are approximately for 5.5° front caster and -2° rear caster, 0.5° front camber and 1° rear camber, 2.5° rear toe-in and 1° front toe-out. Use a setup station or a angle gauge for precise suspension geometry setting. See our recommendations on page #28 for quick and easy suspension geometry change.

### STEP 34

Unscrew **SB25X8** screws on ~3 turns and shift **P04** up to create ~1.5mm gap between **P04** and the lower arm.

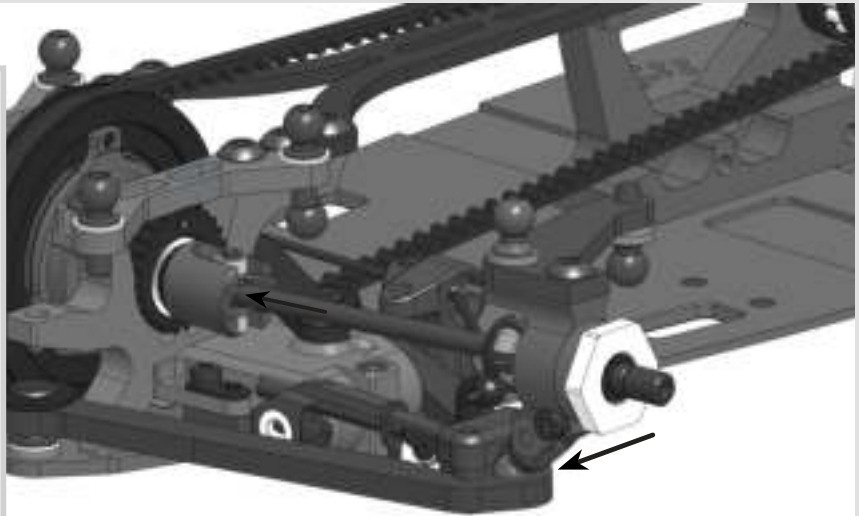

Insert **P03** ball into the spherical cavity of the lower arm and tighten **SB25X8** screws. Insert the driveshaft inner joint into the outdrive of diff/spool.  
**Note:** Don't overtighten **SB25X8** screws to avoid **ST03** ball binding!!! Achieve a free action of the ball joint with a minimal backlash.

### STEP 35

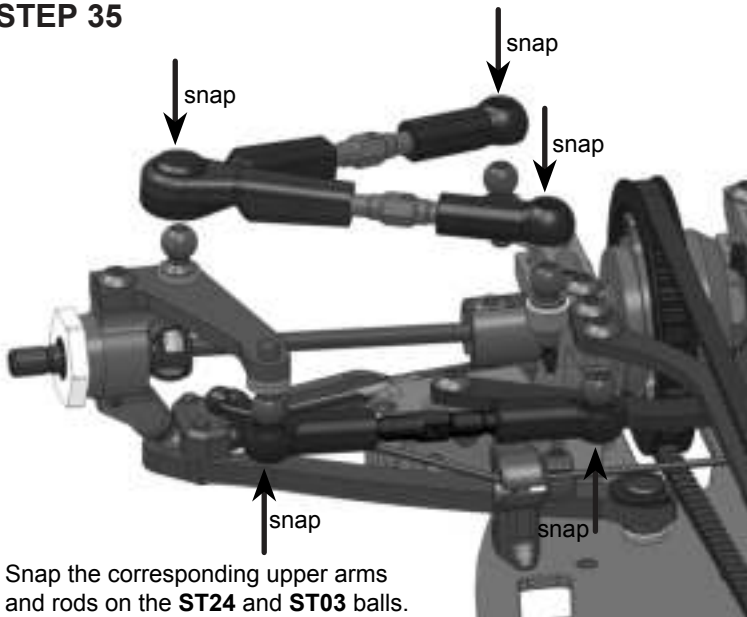

Snap the corresponding upper arms and rods on the **ST24** and **ST03** balls.

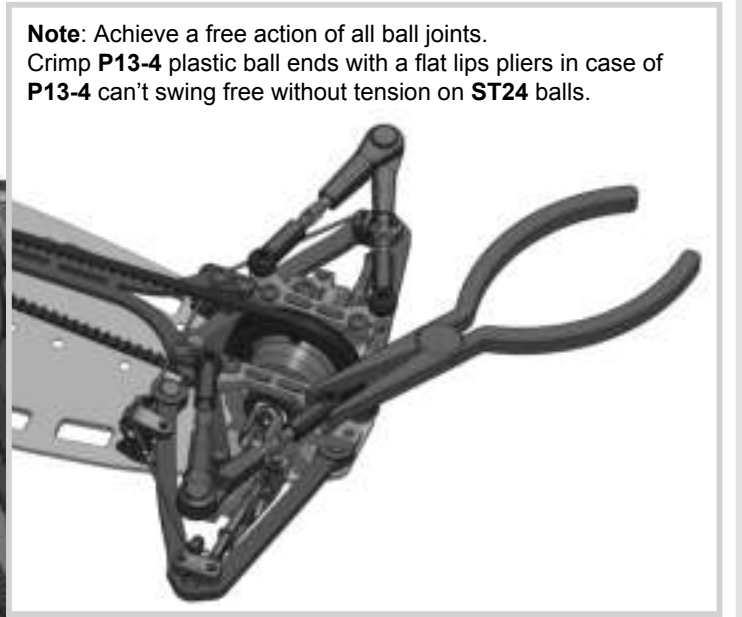

**Note:** Achieve a free action of all ball joints. Crimp **P13-4** plastic ball ends with a flat lips pliers in case of **P13-4** can't swing free without tension on **ST24** balls.

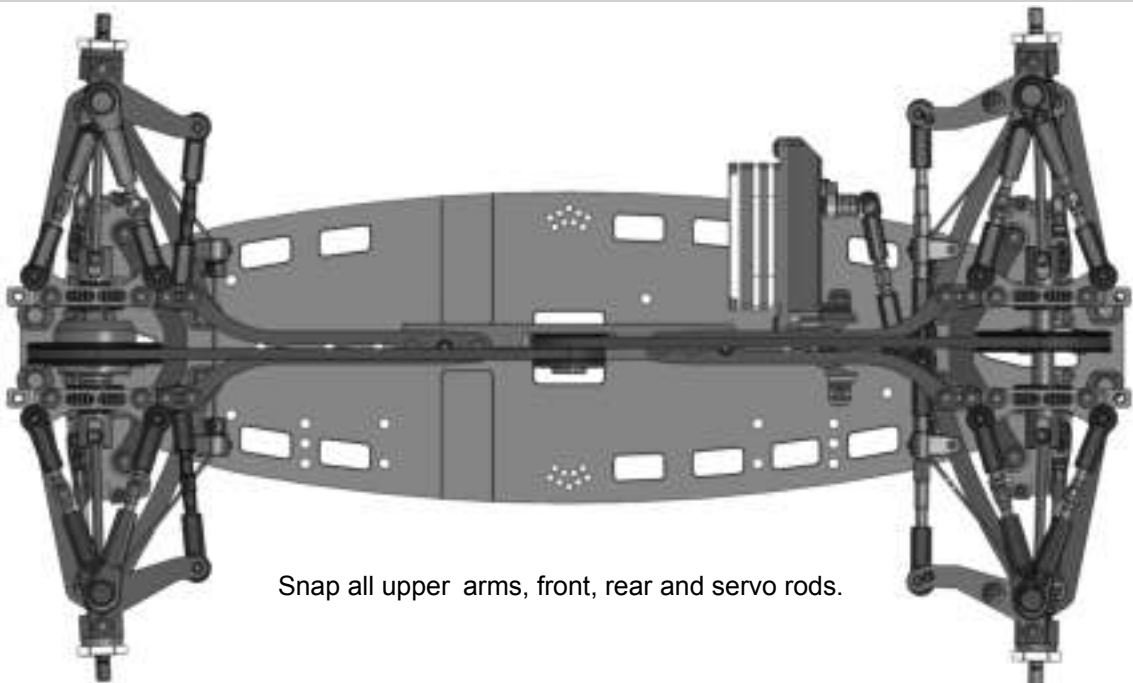

Snap all upper arms, front, rear and servo rods.

### STEP 36

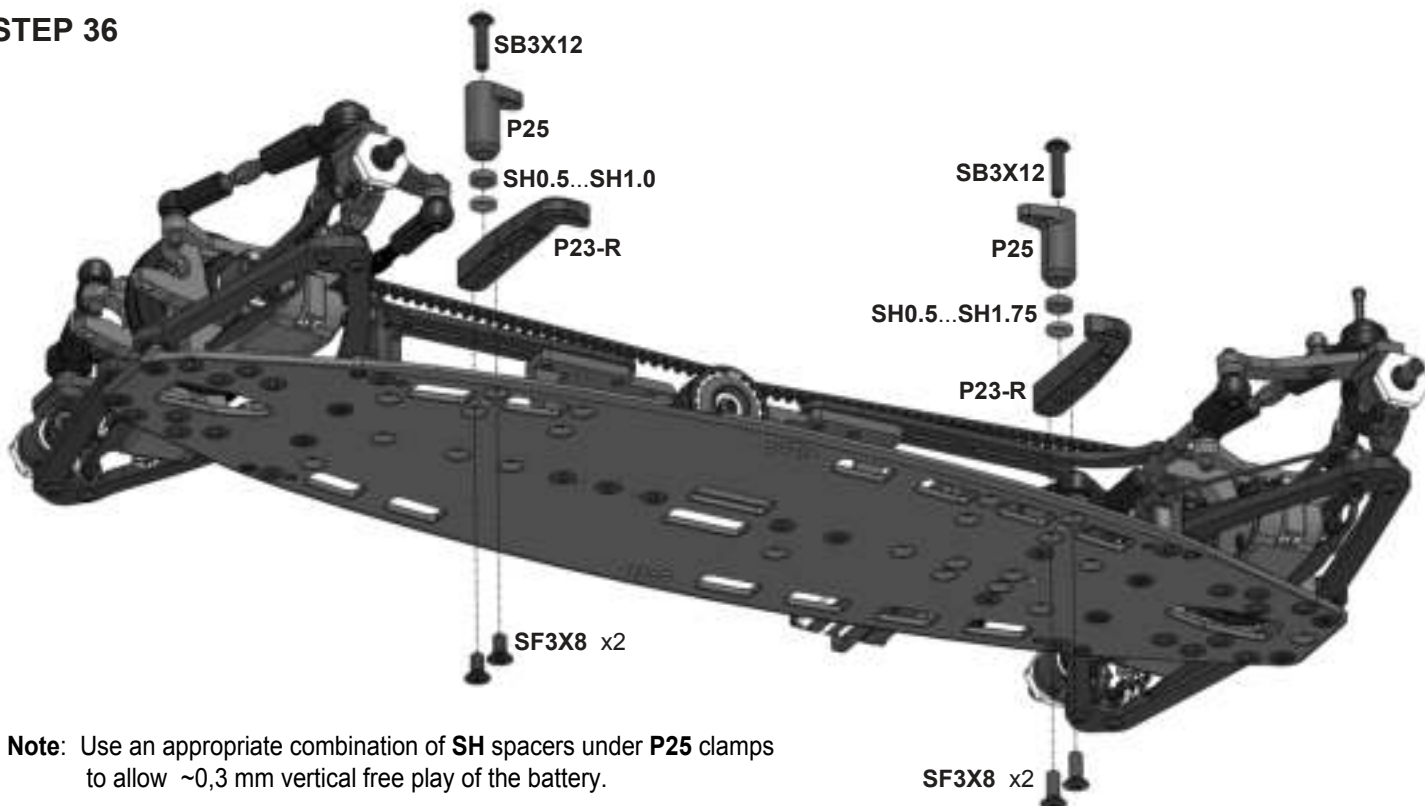

**Note:** Use an appropriate combination of **SH** spacers under **P25** clamps to allow ~0,3 mm vertical free play of the battery.

### STEP 37

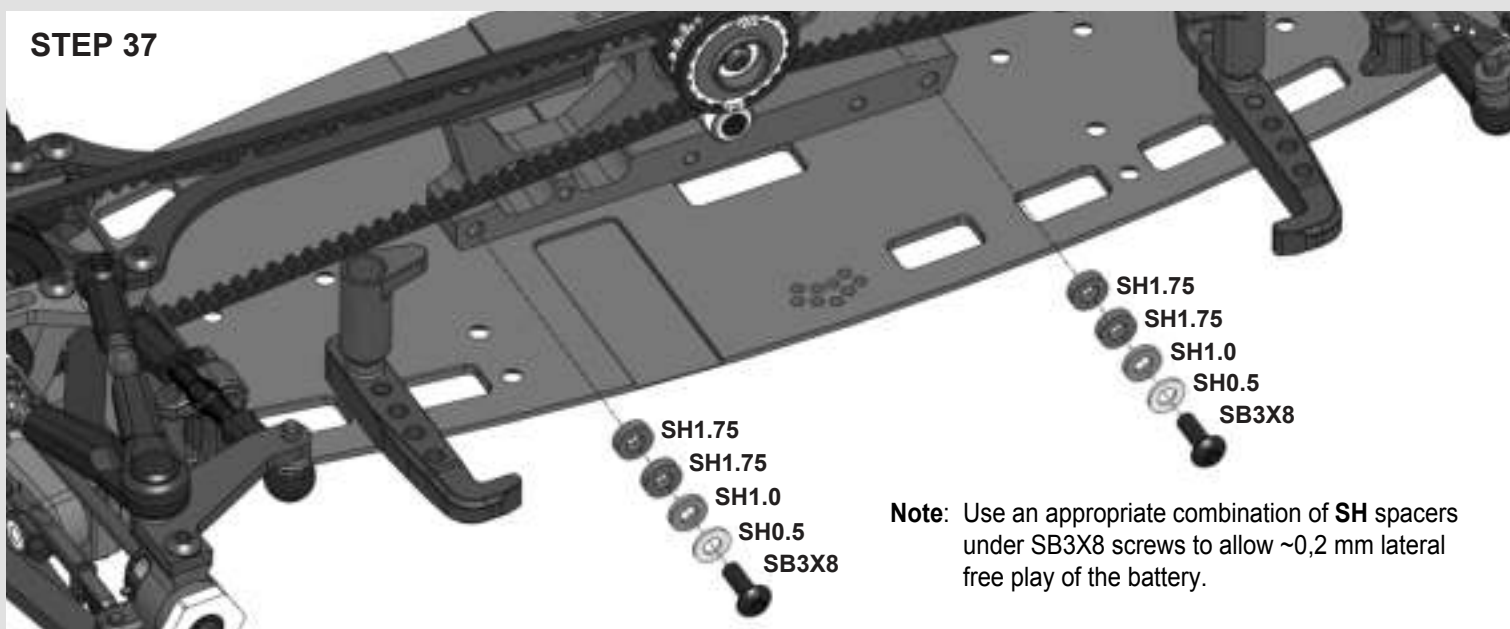

**Note:** Use an appropriate combination of **SH** spacers under **SB3X8** screws to allow ~0,2 mm lateral free play of the battery.

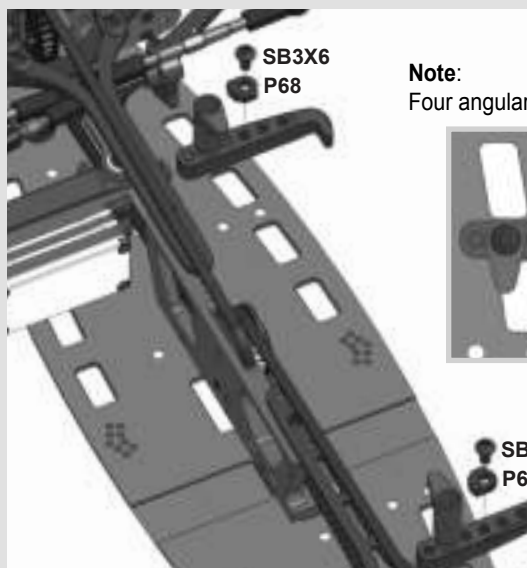

**Note:**

Four angular positions of **P68** adjuster provide 0,25..1,0 mm range for adjusting the longitudinal free play of battery.

### STEP 38





**STEP 39**

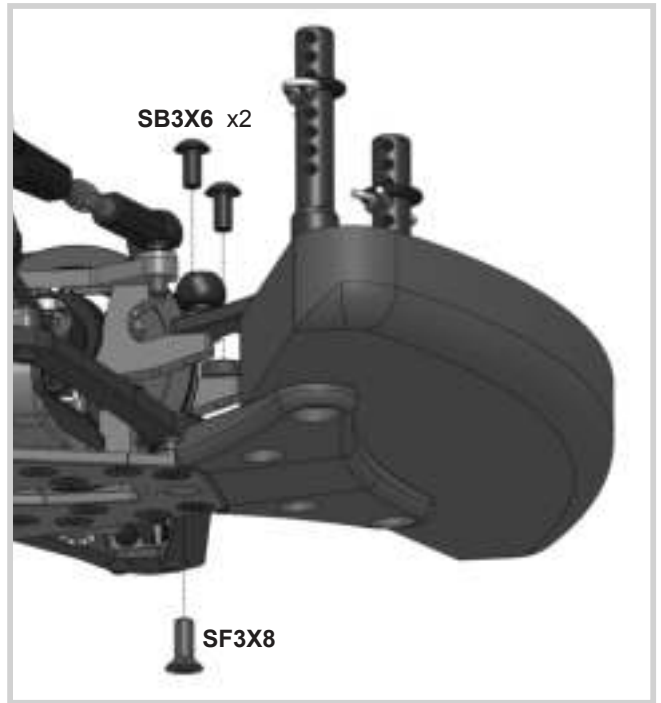
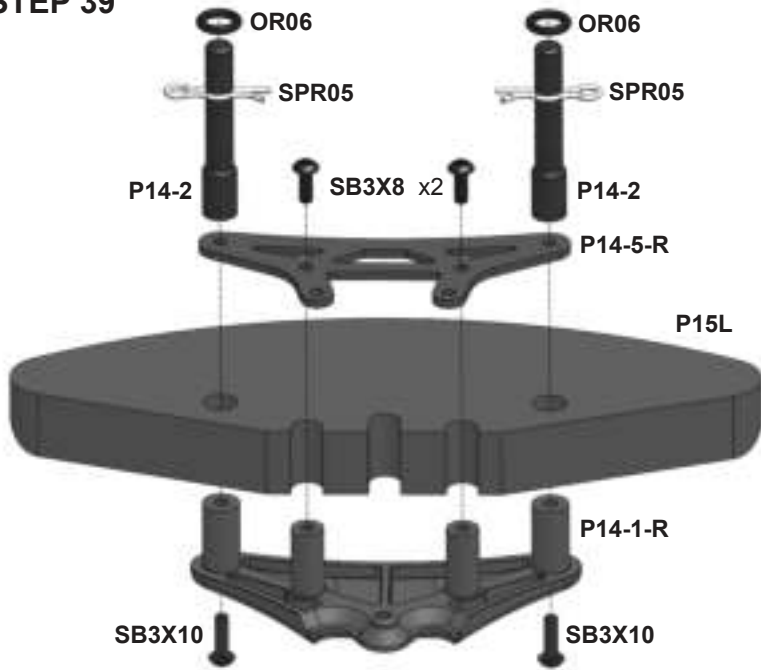

**STEP 40**

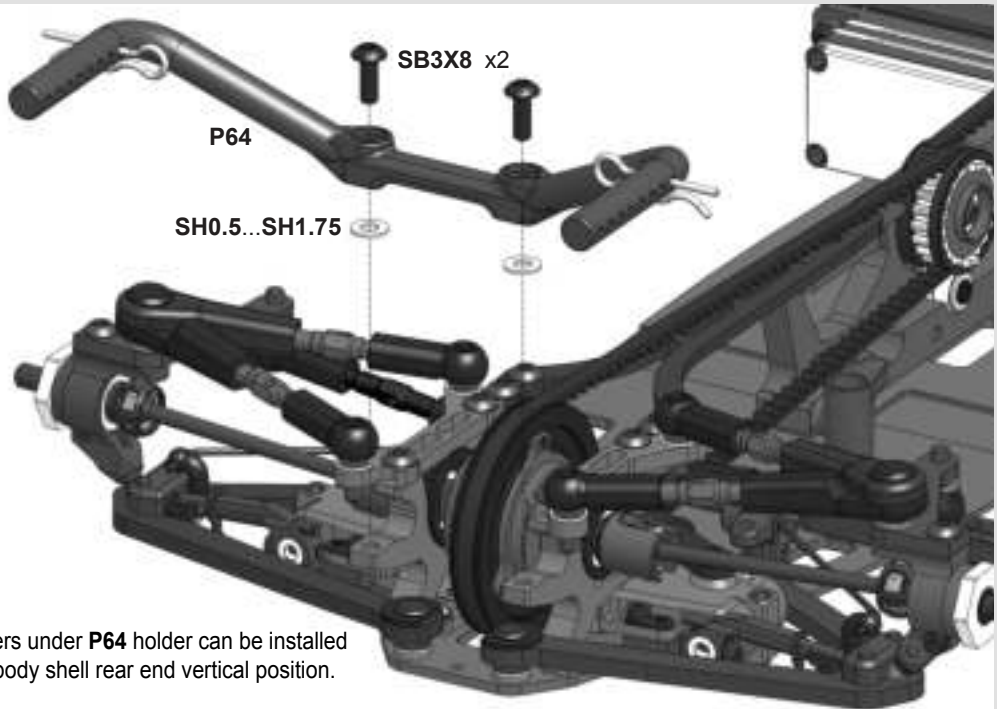
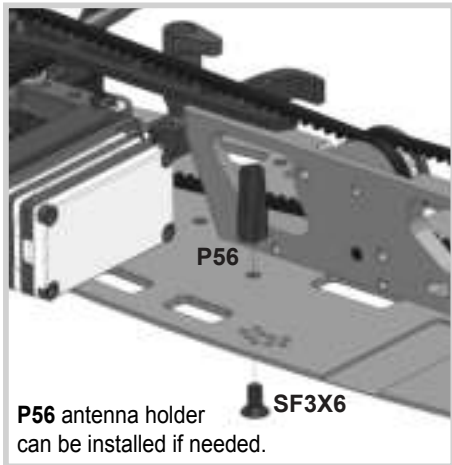

**Note:** SH0.5...SH1.75 spacers under P64 holder can be installed for adjustment of the body shell rear end vertical position.

**STEP 41**

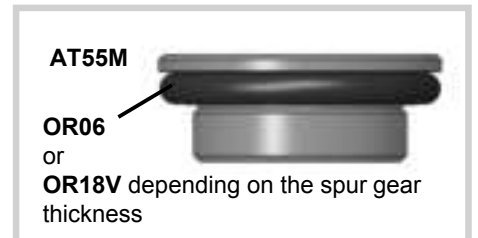
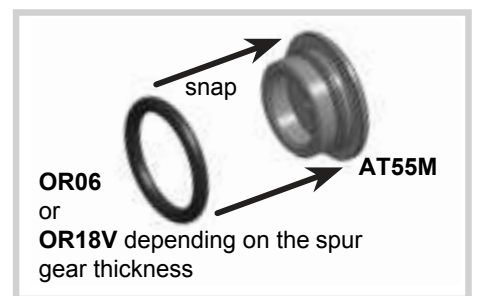
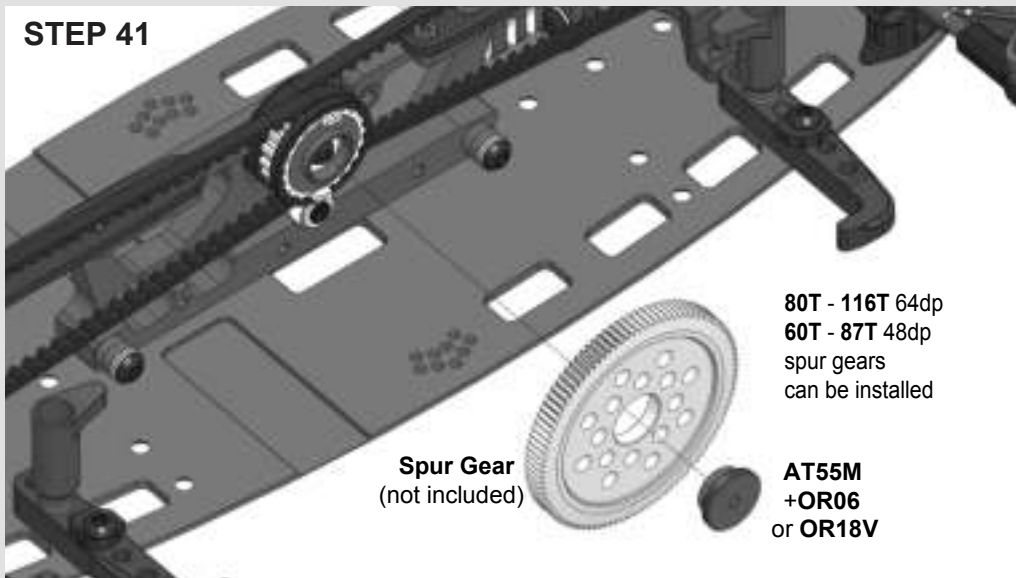

**STEP 42**

19T - 55T 64dp, 14T - 41T 48dp pinion gears can be installed

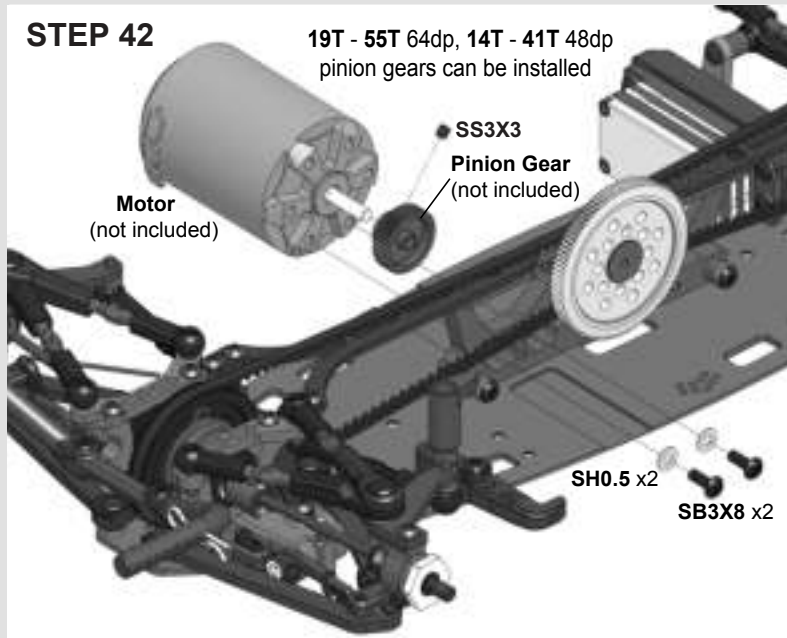

**Note:** This orientation of the hex driver should be used for tightening of the pinion gear set screw.

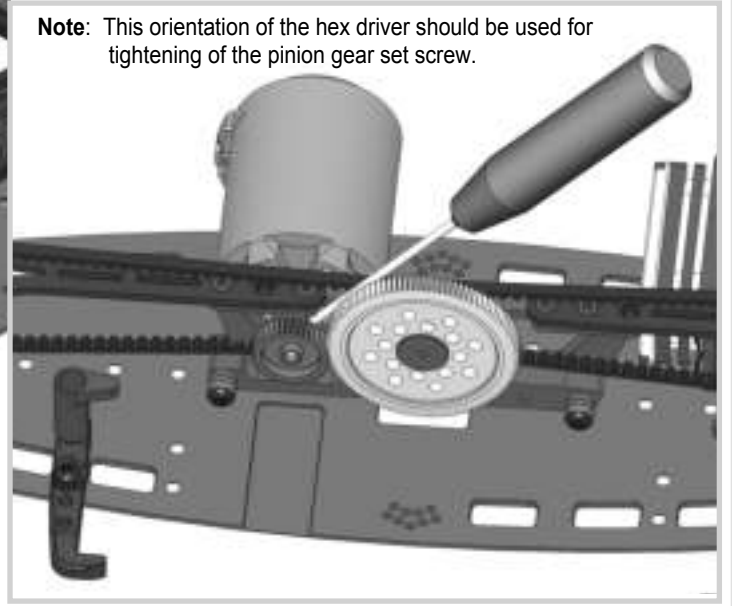

**STEP 43**

**Install:** speed controller (not included), receiver (not included), transponder (not included), battery (not included), motor's fan (not included), wheels (not included).

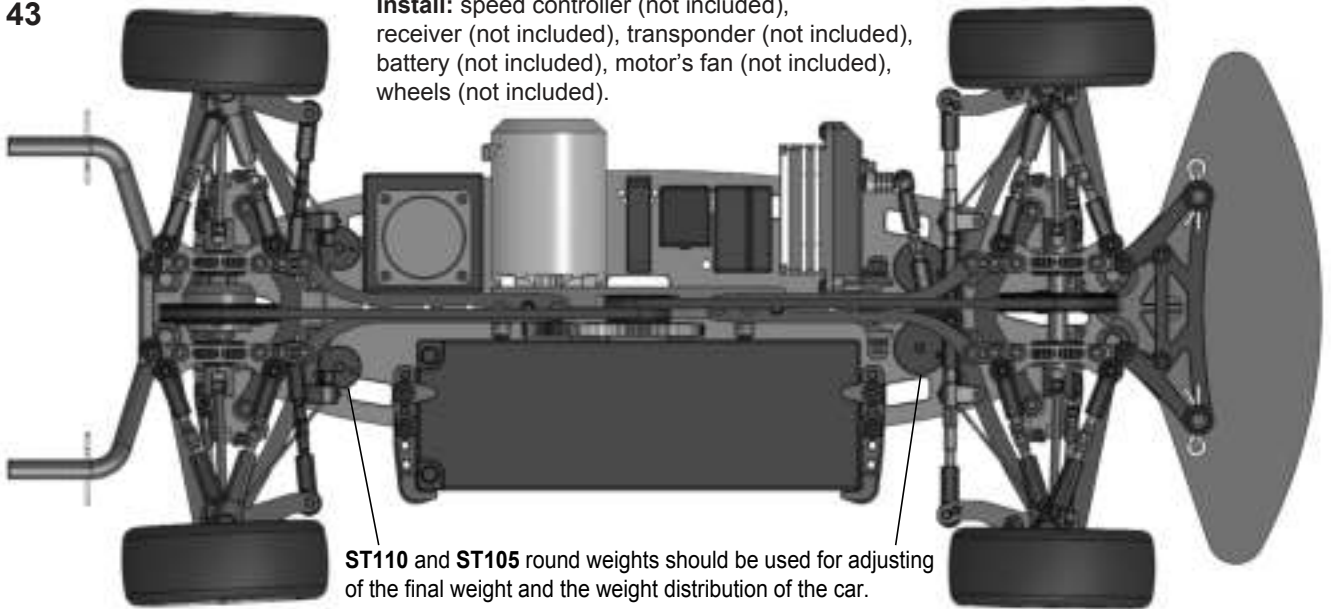

ST110 and ST105 round weights should be used for adjusting of the final weight and the weight distribution of the car.

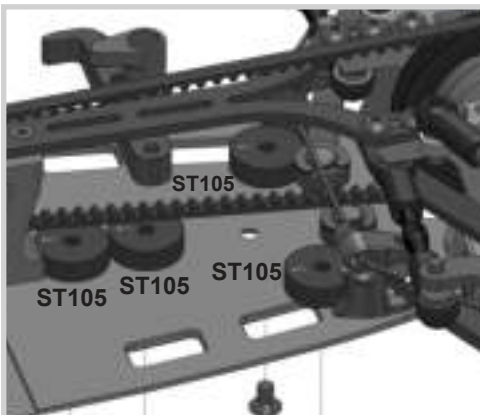

SF3X5 SF3X5 SF3X5 SF3X5

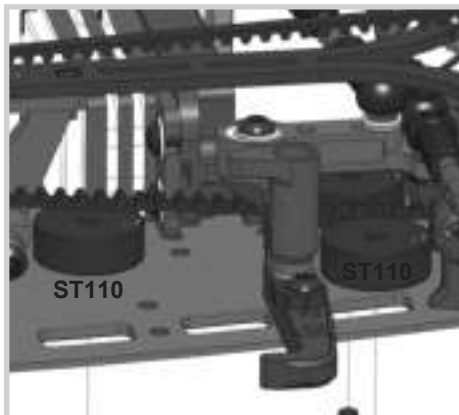

SF3X6 SF3X6 SF3X6

Install **ST110** and **ST105** beveled side down to reduce the effect on car flex.

**ST110**  
or  
**ST105**



The engraved sides of **ST110** and **ST105** are flat. The opposite sides are beveled.

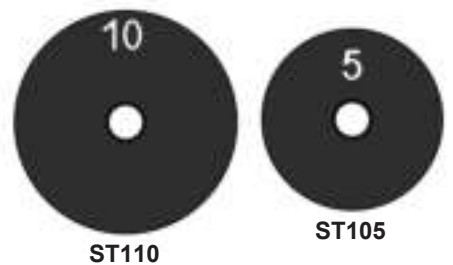

## SUSPENSION SETTING TECHNIQUE

**Camber adjustment rule:** Simultaneous both upper rods 0.5mm shortening (1/2 turn of both turnbuckles) adds 1.0° of camber angle at constant caster.

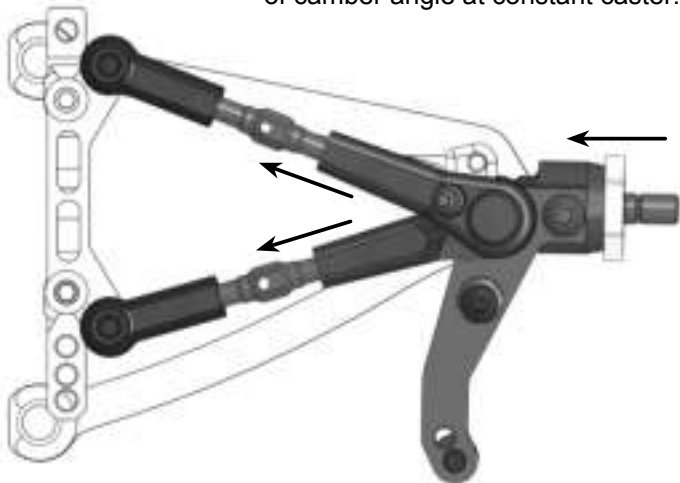

**Caster adjustment rule:** Simultaneous front upper rod 0.5mm elongation and rear upper rod 0.5mm shortening adds 2.5° of caster at constant camber.

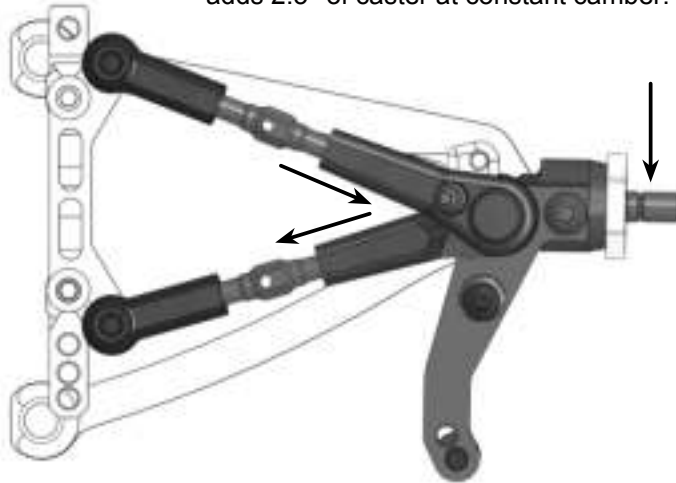

### Caster measuring:

Caster angle° =  
 $(H1-H2)*1.5$  for front  
 $(H1-H2)*1.7$  for rear

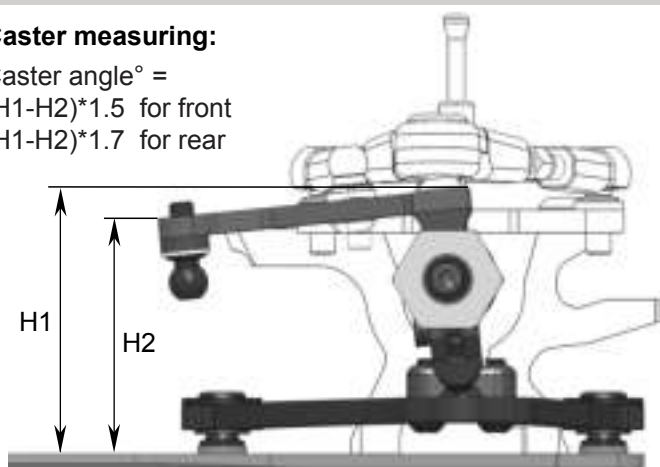

**TIP / Recommendation to use**  
 MAX-02-001 - MXLR Awesomatix Caster Tool

### Wheelbase adjustment:

Use rear suspension caster change for this adjustment.  
 Adding 4°caster shortens wheelbase by 1mm.

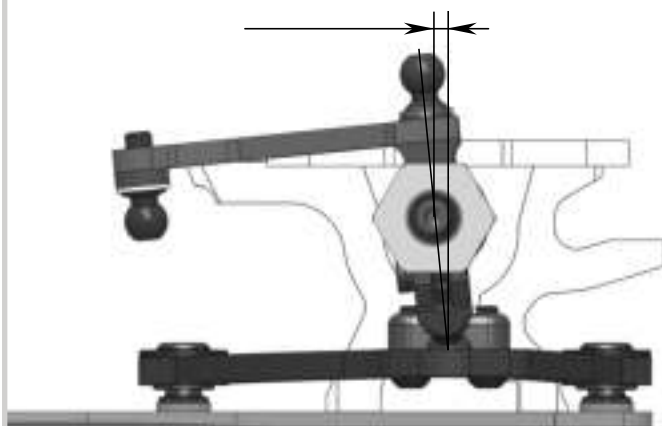

### Rear suspension toe-in adjustment:

Rear rod 0.5mm elongation reduces the toe-in on 1.0°

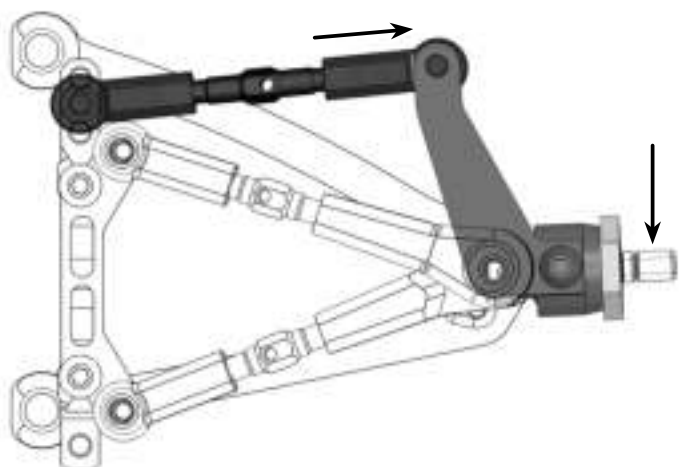

### Body shell front end downtravel adjustment:

Use **SC2X15** screw for adjustment the lowest position of the body shell front splitter.

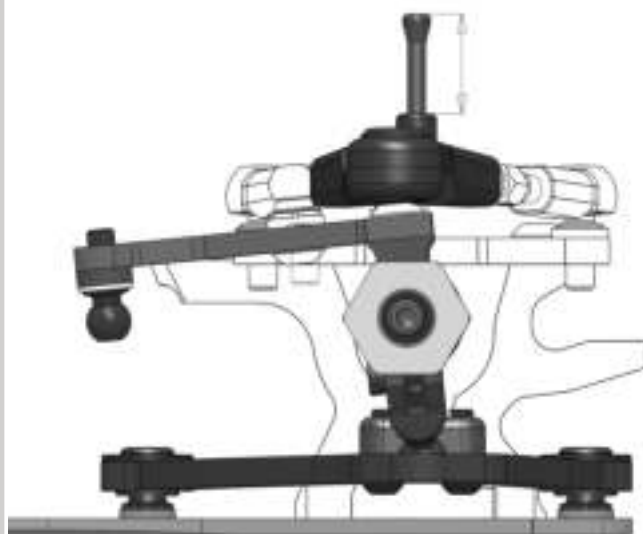

## D3 dampers and suspension springs setting technique

**Attention!** A800R shocks allow to adjust the damping and spring rates without replacement of the shock's fluid and spring.

### 1. Damping and Shock Spring rate setting

Increase **B** distance (slide **AT119** holder outward) to increase the spring rate. Reduce **B** distance (slide **AT119** holder inward) to reduce the spring rate. Use **SRS** (Spring Rating Screw) to unlock **AT119** holder and to lock it at the desirable position.

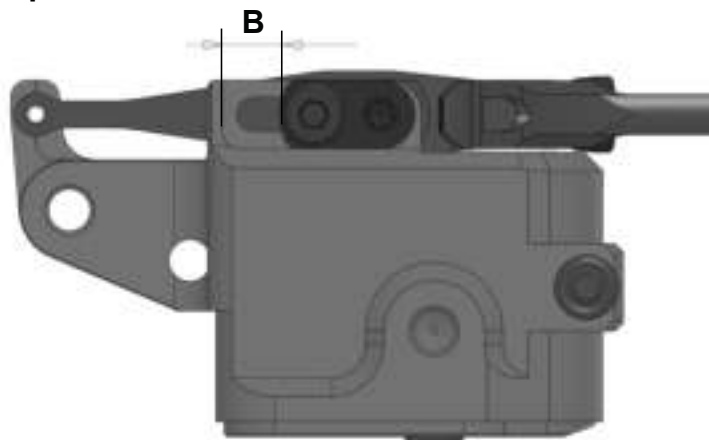

### 2. Shock Spring preload setting

Spring preload and the ride height of the car is adjusting via **RHS** (Ride Height Screw). In A800R kit **ST69-00** screw is used as **RHS** screw. Turn IN (CW) **RHS** screw to increase spring preload. Turn OUT (CCW) **RHS** screw to decrease spring preload. Use spring preload setting to adjust ride height value.

### 3. SRS/RHS Screws arrangements

The reverse arrangement of these screws is possible also.

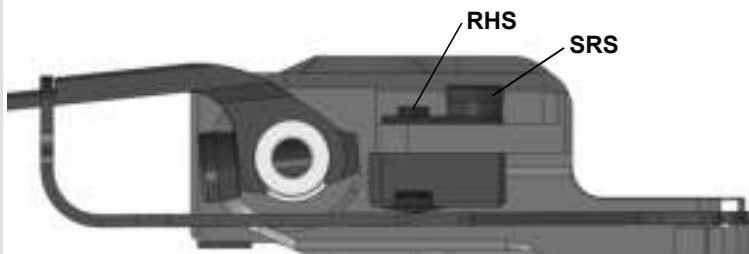

SRS/RHS screws arrangement I

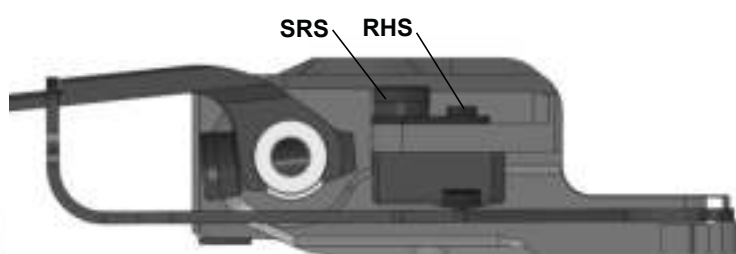

SRS/RHS Screws arrangement II

### 4. Damping level setting

**ST143** valve angular position indicates the damping level from 60% to 100% at 5% increment.



60%



80%



100%

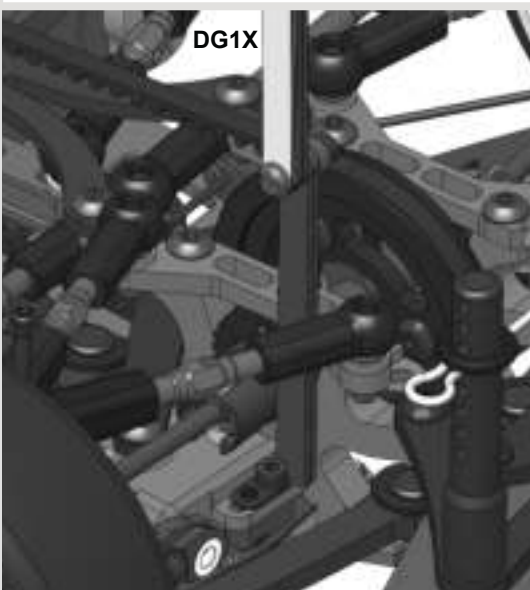

### 5. DG1X gauge using

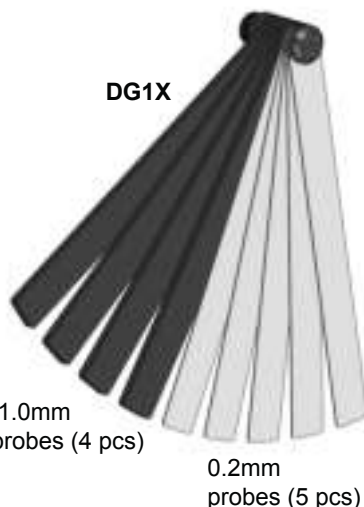

# Optional parts and sets

## C07-R carbon bumper plate

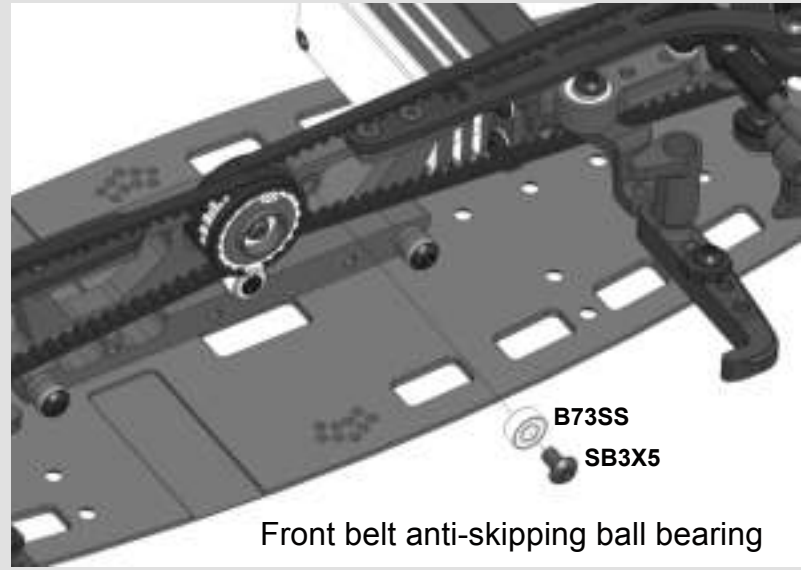
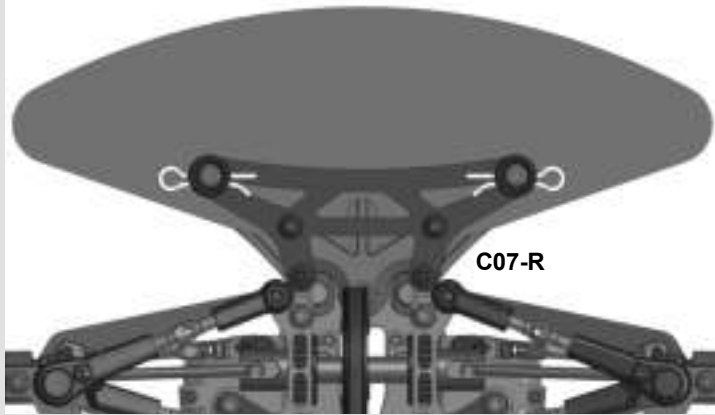

## BW27 27 g stiffener

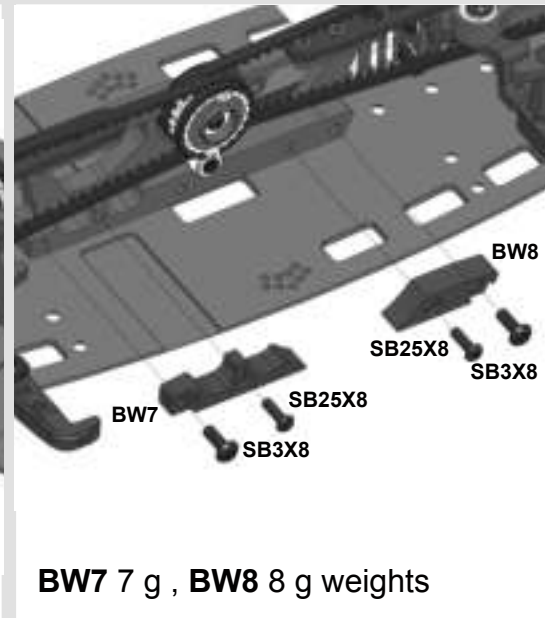
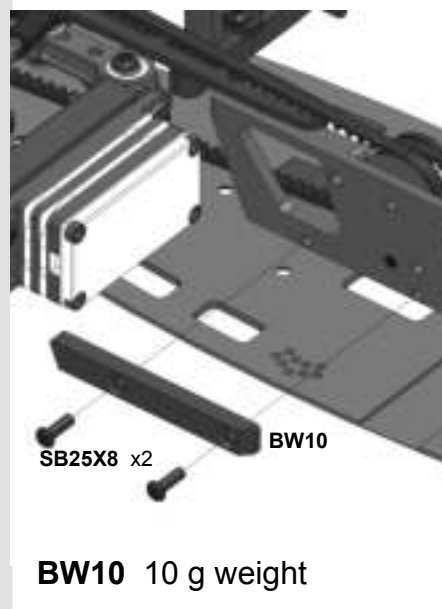
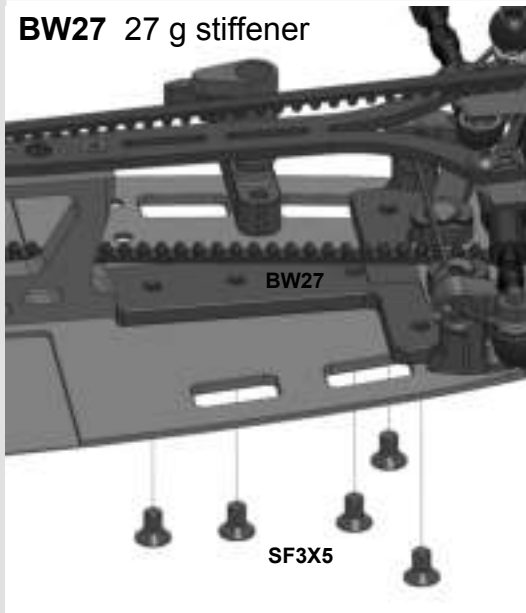

## C26 top stiffener

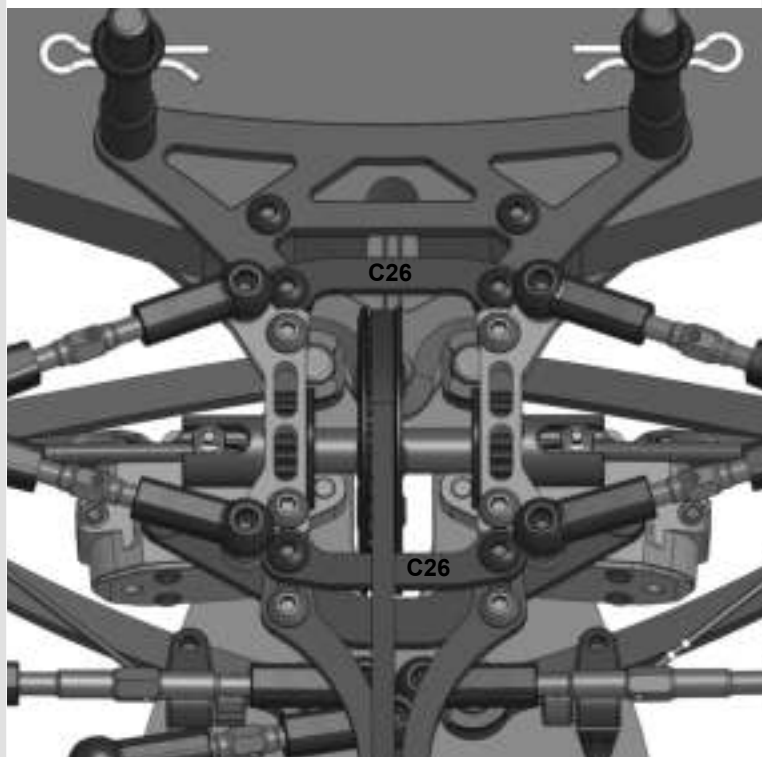

## AT139 fan holder

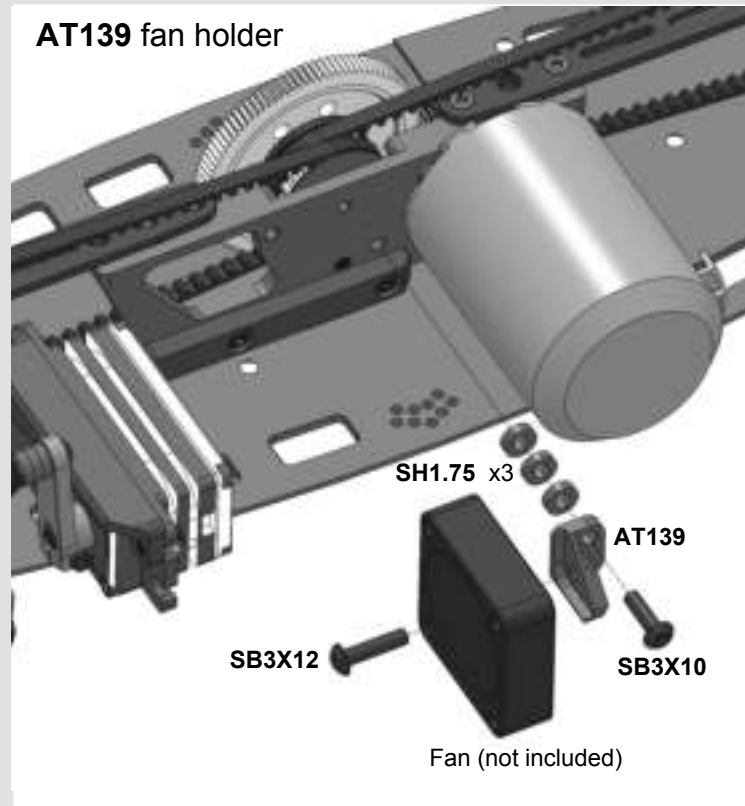

# Optional parts and sets

## BW22R and AT144

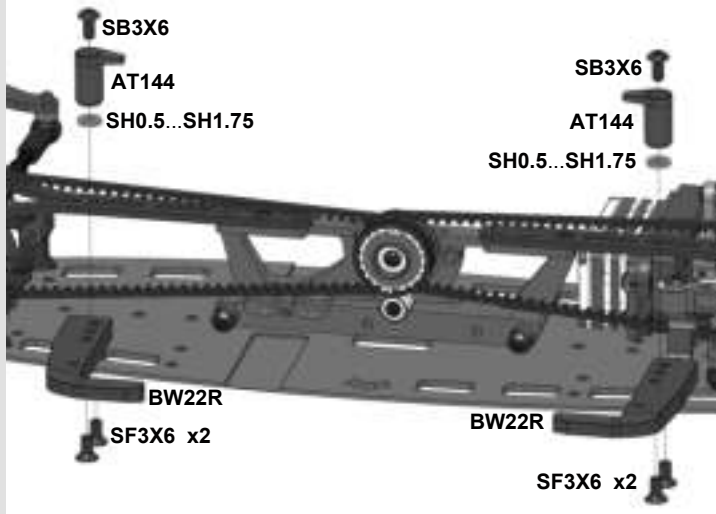

## BW52R and AT144

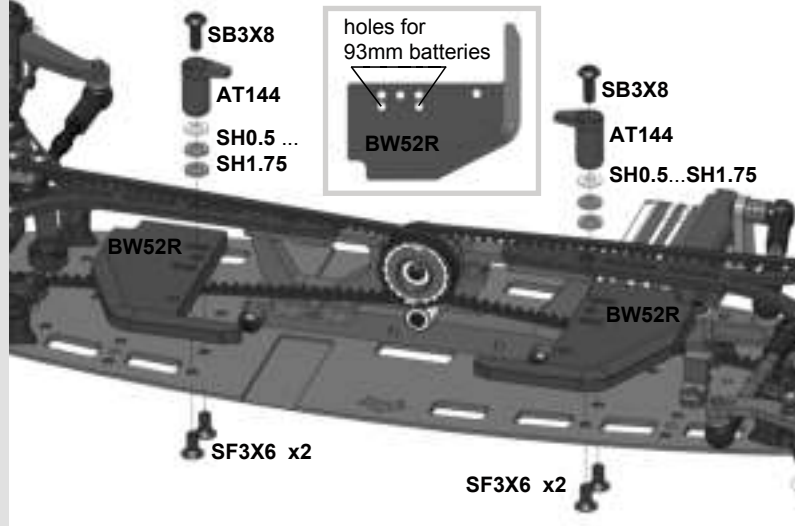

## AT143 anti-roll bar stiffener

AT143 stiffener increases stiffness of the anti-roll bar up to one step.  
**+1 step** stiffness increasing means that  
 1.0 mm bar acts like 1.1 mm bar  
 1.1 mm bar acts like 1.2 mm bar  
 1.2 mm bar acts like 1.3 mm bar  
 1.3 mm bar acts like 1.4 mm bar.  
**1/2** and **1/4** steps of increasing are possible to set.

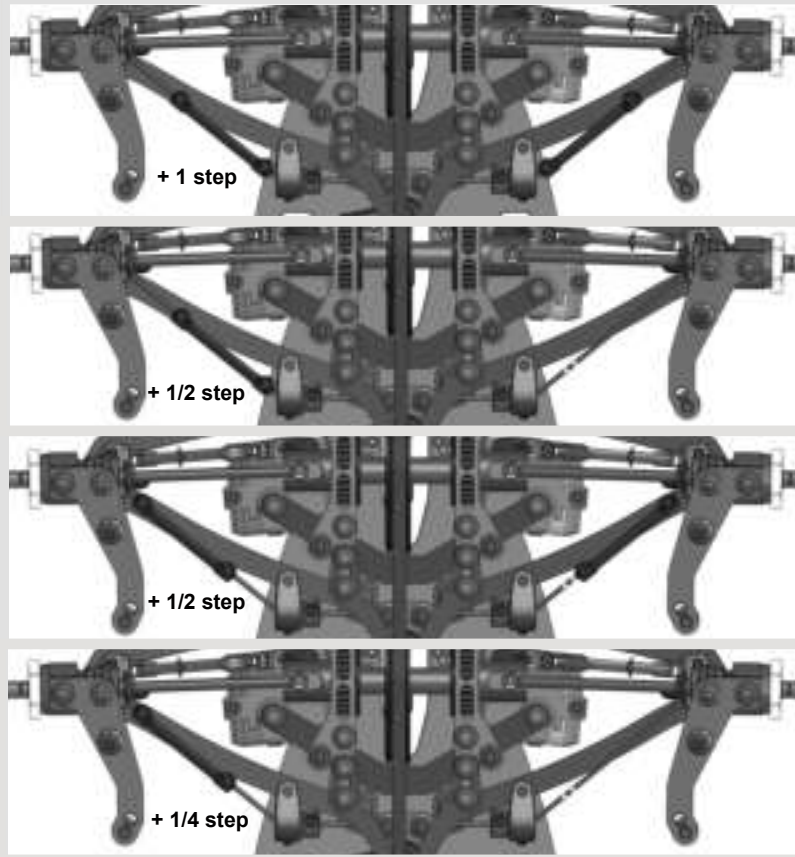
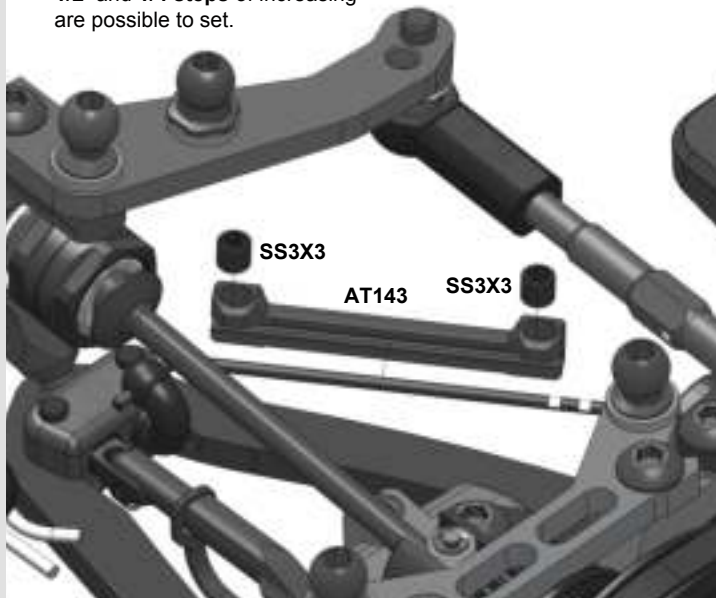

FRONT

REAR

## Front/Rear weight distribution measuring holes on the lower deck.

F52/R48%   F51.5/R48.5%   F51/R49%   F50.5/R49.5%   F50/R50%  
 F48/R52%   F48.5/R51.5%   F49/R51%   F49.5/R50.5%



NAME \_\_\_\_\_  
 COUNTRY \_\_\_\_\_  
 RACE \_\_\_\_\_  
 TRACK \_\_\_\_\_

DATE \_\_\_\_\_ TEMP. °C AIR / TRACK / \_\_\_\_\_  
 TRACK SURFACE ASPHALT  CARPET   
 TRACK LAYOUT TECHNICAL  MIXED  FAST   
 TRACTION LOW  MEDIUM  HIGH

### FRONT

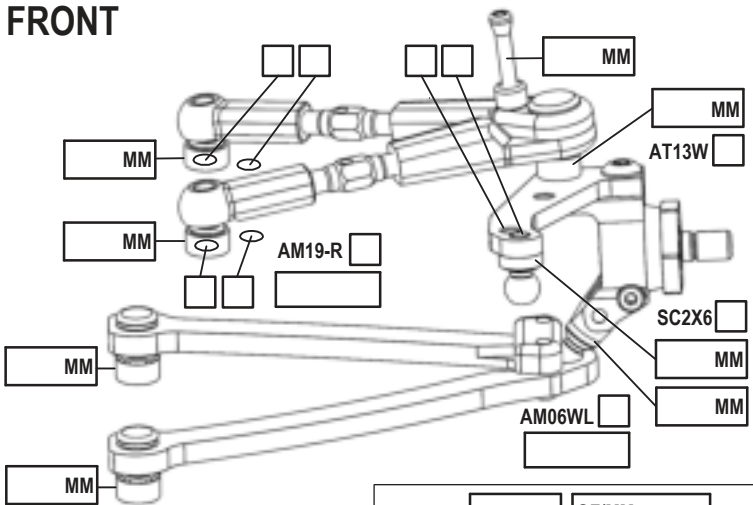

CAMBER ANGLE / ° \_\_\_\_\_  
 CASTER ANGLE / ° \_\_\_\_\_  
 TOE ANGLE / ° \_\_\_\_\_  
 RIDE HEIGHT / MM \_\_\_\_\_  
 DOWNSTOP / MM \_\_\_\_\_  
 ANTI-ROLL BAR Ø / MM \_\_\_\_\_  
 ARB STIFFENER 1/4  1/2  3/4  1   
 LOWER ARM EXTENSION \_\_\_\_\_ MM  
 STEER. ARM AM14LS   
 WHEEL SPACER / MM \_\_\_\_\_  
 DRIVE SPOOL  DIFF   
 DRIVE POSITION UP  DOWN   
 DIFF OIL \_\_\_\_\_ DIFF SHIMS \_\_\_\_\_

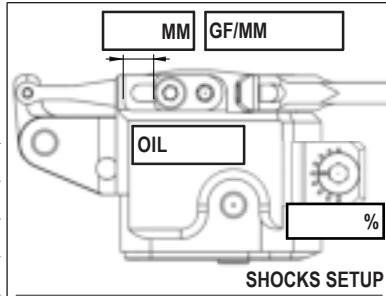

**SHOCKS SETUP**

DAMPER D3   
 ROTOR 2 HOLES   
 SPRING STD  S   
 SRS/RHS ARR. I  II   
 PSS SETUP 25%  15%   
 DAMPING LINEAR  PROGRESSIVE   
 C45 YES  NO   
 2ND SPRING SPR-P1

### REAR

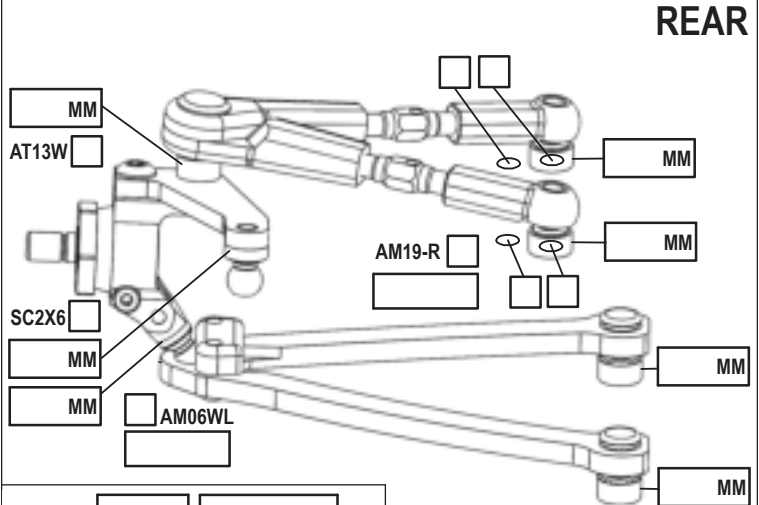

CAMBER ANGLE / ° \_\_\_\_\_  
 CASTER ANGLE / ° \_\_\_\_\_  
 TOE ANGLE / ° \_\_\_\_\_  
 RIDE HEIGHT / MM \_\_\_\_\_  
 DOWNSTOP / MM \_\_\_\_\_  
 ANTI-ROLL BAR Ø / MM \_\_\_\_\_  
 ARB STIFFENER 1/4  1/2  3/4  1   
 LOWER ARM EXTENSION \_\_\_\_\_ MM  
 STEER. ARM AM23-R   
 WHEEL SPACER / MM \_\_\_\_\_  
 DRIVE (surprise us) \_\_\_\_\_  
 DRIVE POSITION UP  DOWN   
 DIFF OIL \_\_\_\_\_ DIFF SHIMS \_\_\_\_\_

**SHOCKS SETUP**

DAMPER D3   
 ROTOR 2 HOLES   
 SPRING STD  S   
 SRS/RHS ARR. I  II   
 PSS SETUP 25%  15%   
 DAMPING LINEAR  PROGRESSIVE   
 C45 YES  NO   
 2ND SPRING SPR-P1

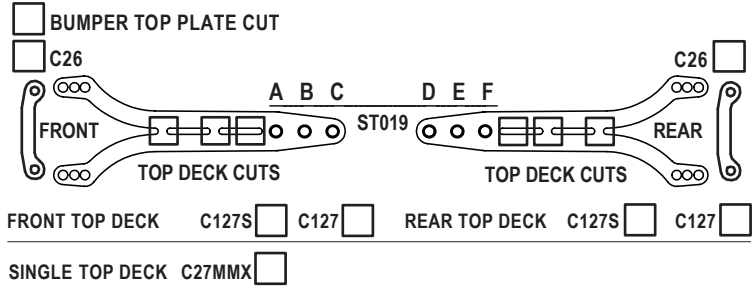
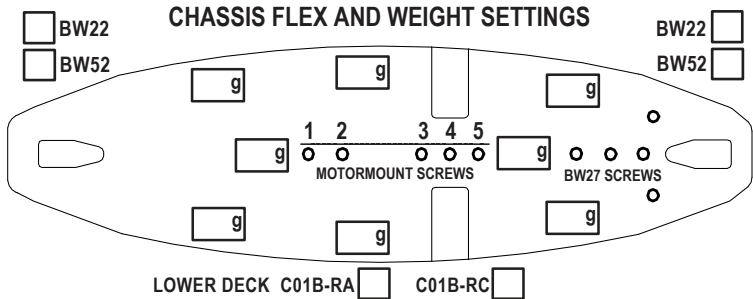

**TIRES** \_\_\_\_\_  
 INSERTS \_\_\_\_\_  
 WHEELS \_\_\_\_\_  
 ADDITIVE \_\_\_\_\_ TIME - FR \_\_\_\_\_ RR \_\_\_\_\_  
 TOTAL WEIGHT \_\_\_\_\_ WEIGHT DISTRIBUTION F % R %

NOTES: \_\_\_\_\_

MOTOR LATERAL SHIFT / MM \_\_\_\_\_ ACKERMANN SHIMS / MM \_\_\_\_\_  
 MOTOR \_\_\_\_\_ SERVO \_\_\_\_\_  
 SPUR PINION RATIO \_\_\_\_\_ STEER TRAVEL IN \_\_\_\_\_ OUT \_\_\_\_\_  
 BODY \_\_\_\_\_ BATTERY \_\_\_\_\_  
 WING \_\_\_\_\_ RECEIVER \_\_\_\_\_  
 ESC \_\_\_\_\_ RADIO \_\_\_\_\_  
 ESC SETTING \_\_\_\_\_  
 BEST LAP TIME \_\_\_\_\_ QUALIF./FINAL POSITION / \_\_\_\_\_

COMMENTS: \_\_\_\_\_



NAME **BASIC CARPET SETUP**

COUNTRY \_\_\_\_\_

RACE \_\_\_\_\_

TRACK \_\_\_\_\_

DATE \_\_\_\_\_ TEMP. °C AIR / TRACK / \_\_\_\_\_

TRACK SURFACE ASPHALT  CARPET

TRACK LAYOUT TECHNICAL  MIXED  FAST

TRACTION LOW  MEDIUM  HIGH

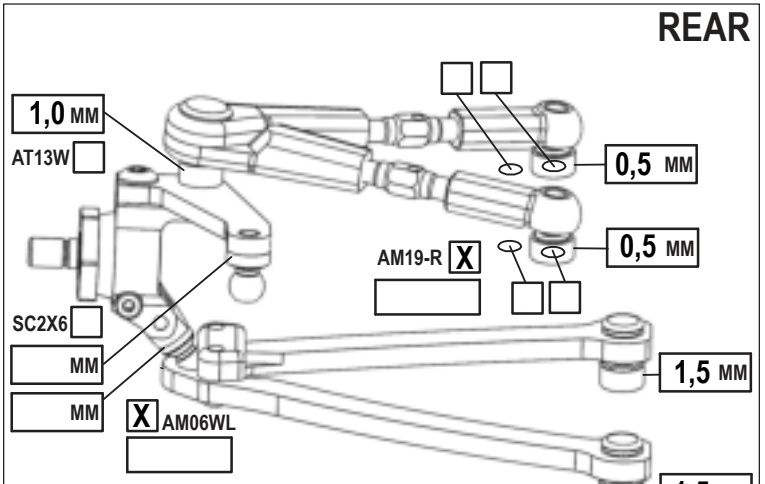
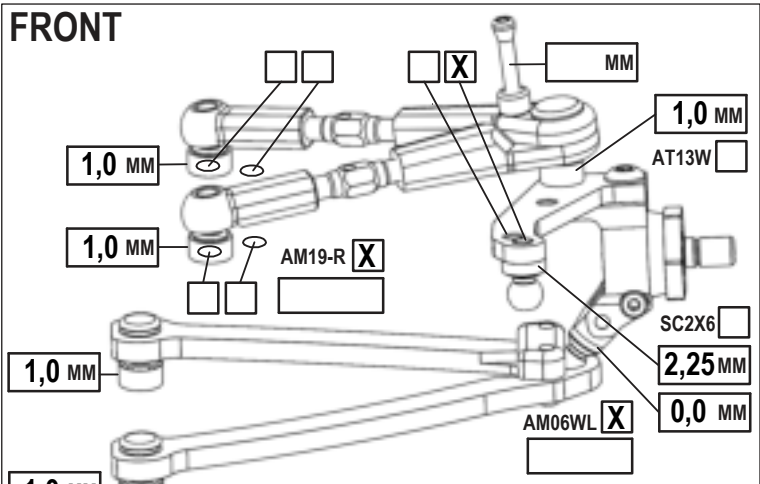

CAMBER ANGLE / °	<b>0,5</b>
CASTER ANGLE / °	<b>5,5</b>
TOE ANGLE / °	<b>-1,0 each side</b>
RIDE HEIGHT / MM	<b>5,2</b>
DOWNSTOP / MM	<b>6,2</b>
ANTI-ROLL BAR Ø / MM	<b>1,2</b>
ARB STIFFENER 1/4 <input type="checkbox"/> 1/2 <input type="checkbox"/> 3/4 <input type="checkbox"/> 1 <input type="checkbox"/>	
LOWER ARM EXTENSION	<b>0 MM</b>
STEER. ARM AM14LS <input checked="" type="checkbox"/>	
WHEEL SPACER / MM	
DRIVE SPOOL <input checked="" type="checkbox"/> DIFF <input type="checkbox"/>	
DRIVE POSITION UP <input type="checkbox"/> DOWN <input checked="" type="checkbox"/>	
DIFF OIL	DIFF SHIMS

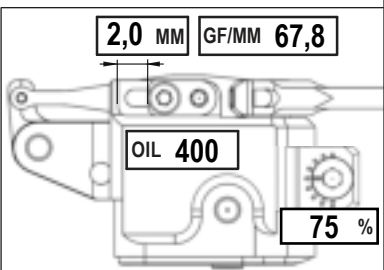

DAMPER D3 <input checked="" type="checkbox"/>	
ROTOR 2 HOLES <input checked="" type="checkbox"/>	
SPRING STD <input type="checkbox"/> s <input checked="" type="checkbox"/>	
SRS/RHS ARR. I <input checked="" type="checkbox"/> II <input type="checkbox"/>	
PSS SETUP 25% <input type="checkbox"/> 15% <input type="checkbox"/>	
DAMPING LINEAR <input checked="" type="checkbox"/> PROGRESSIVE <input type="checkbox"/>	
C45 YES <input checked="" type="checkbox"/> NO <input type="checkbox"/>	
2ND SPRING SPR-P1 <input type="checkbox"/>	

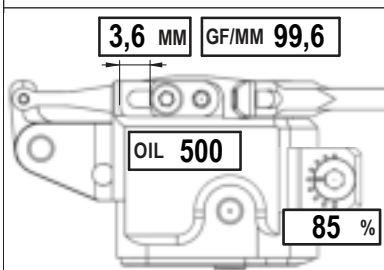

DAMPER D3 <input checked="" type="checkbox"/>	
ROTOR 2 HOLES <input checked="" type="checkbox"/>	
SPRING STD <input type="checkbox"/> s <input checked="" type="checkbox"/>	
SRS/RHS ARR. I <input checked="" type="checkbox"/> II <input type="checkbox"/>	
PSS SETUP 25% <input type="checkbox"/> 15% <input type="checkbox"/>	
DAMPING LINEAR <input checked="" type="checkbox"/> PROGRESSIVE <input type="checkbox"/>	
C45 YES <input checked="" type="checkbox"/> NO <input type="checkbox"/>	
2ND SPRING SPR-P1 <input type="checkbox"/>	

CAMBER ANGLE / °	<b>1,0</b>
CASTER ANGLE / °	<b>-2,0</b>
TOE ANGLE / °	<b>2,5</b>
RIDE HEIGHT / MM	<b>5,4</b>
DOWNSTOP / MM	<b>4,2</b>
ANTI-ROLL BAR Ø / MM	<b>1,2</b>
ARB STIFFENER 1/4 <input type="checkbox"/> 1/2 <input type="checkbox"/> 3/4 <input type="checkbox"/> 1 <input type="checkbox"/>	
LOWER ARM EXTENSION	<b>0 MM</b>
STEER. ARM AM23-R <input checked="" type="checkbox"/>	
WHEEL SPACER / MM	
DRIVE (surprise us)	
DRIVE POSITION UP <input type="checkbox"/> DOWN <input checked="" type="checkbox"/>	
DIFF OIL <b>10K</b>	DIFF SHIMS <b>STD</b>

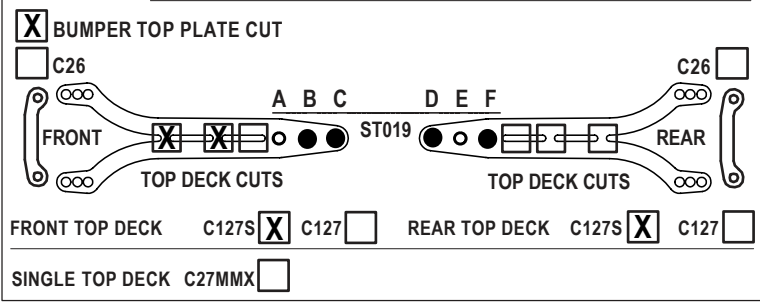
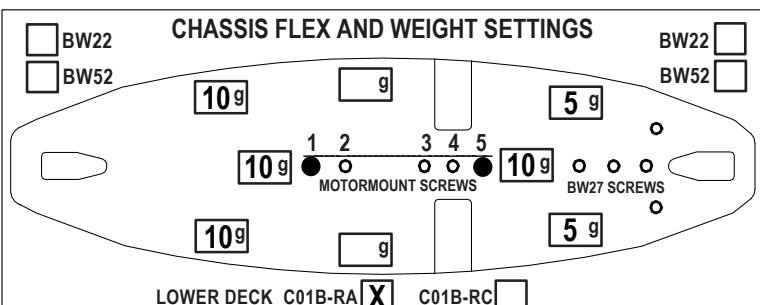

### TIRES

INSERTS \_\_\_\_\_

WHEELS \_\_\_\_\_

ADDITIVE \_\_\_\_\_ TIME - FR RR

TOTAL WEIGHT \_\_\_\_\_ WEIGHT DISTRIBUTION F **49 %** R **51 %**

NOTES: \_\_\_\_\_

MOTOR LATERAL SHIFT / MM	ACKERMANN SHIMS / MM <b>center</b>
MOTOR	SERVO
SPUR PINION RATIO	STEER TRAVEL IN <b>23,5</b> OUT <b>16</b>
BODY	BATTERY
WING	RECEIVER
ESC	RADIO
ESC SETTING	
BEST LAP TIME	QUALIF./FINAL POSITION /

COMMENTS:

## Standard Spare Parts

Parts#	Description	Parts#	Description
AM06WL	Steering Block	P25	Battery Clamp
AM14LS	Steering Arm	P39	GD2 Cross Pin
AM19-R	Upper Arm Holder	P46R	Diff Piston
AM23-R	Rear Steering Arm	P56	Antenna Holder
AM24-20	Central Servo Holder	P63	Damper Piston
AM240	Damper Cover	P263	Damper Membrane
AM242L	Damper Body L	P64	Rear Body Holder
AM242R	Damper Body R	P67	Dampers Stand Plate
AM278	Bulkhead	P68	Battery Adjuster
AM177-2	Motor Mount	P110	Bearing Housing
AM180EVO	SB Bellcrank	P138-1	38T Pulley
AT03BX	Spool Axle	P138S-1	Spool 38T Pulley
AT13	Wheel Hex	C01B-RC	Lower Deck Carbon
AT14	Turnbuckle	C01B-RA	Lower Deck Alloy
AT21ST-A	Pivot Ball Steel	C45F	Dampers Brace Front
AT25	Turnbuckle Long	C45R	Dampers Brace Rear
AT25-44	Turnbuckle 44mm	C127	Top Deck
AT241	Damper Rotor	C127S	Top Deck
AT243	Progression Damper Plate	C204R	Suspension Arm
AT247	Damper Piston Probe	C204L	Suspension Arm
AT55M	Spur Nut	SWB-R-1.0	Sway Bar 1.0mm
AT119	Spring Screw Holder	SWB-R-1.1	Sway Bar 1.1mm
AT120XB	20T Alloy Pulley	SWB-R-1.2	Sway Bar 1.2mm
AT123B	GD2B Case1	SWB-R-1.3	Sway Bar 1.3mm
AT124B	GD2B Case2	SPR01	Shock Spring
AT142	Sway Bar Stopper	SPR01S	Shock Spring Soft
ST01	Front Axle	SPR23	Shock Pointer
ST02	Rear Axle	SPR05	Body Clip
ST03	Ball Stud	SPR07	E-Ring
ST113	IFJ Universal Bone	SH0.5	6x3x0.5mm Spacer (Silver)
ST114	IRJ Universal Bone	SH1.0	6x3x1.0mm Spacer (Gray)
ST116	IFJ/IRJ Cross	SH1.75	6x3x1.75mm Spacer (Black)
ST16	U-Joint Cross	SH0.1	6x8x0.1mm Shim
ST17-1	Universal Ring	WA02	3x5x0.2 Washer
ST019	Top Deck Screw	WA03	5x15x0.3 Washer
ST23X	IRJ Outdrive	PIN01	1.5x7.8 Pin
ST24	4,8x6mm Ball Stud	PIN02	1.5x5.8 Pin
ST31-1	GD2 Output Axle	OR13	1x13 mm O-ring
ST37X	IFJ Outdrive	OR05V	GD O-Ring Viton
ST38	Universal Nut	OR06	5.5mm O-ring
ST59	LS2 Long Screw	OR1705V	O-Ring 17x0.5 Viton
ST68	Flanged Wheel Nut	OR1010V	O-ring 1x1 Viton
ST69-00	Linear Spring Screw	OR2010V	O-ring 2x1 Viton
ST102F	Damper Rod Guide Front	B106RS	B106RS Ball Bearing
ST102R	Damper Rod Guide Rear	B85	B85 Ball Bearing
ST105	5g Round Weight	B84SS	B84SS Ball Bearing
ST110	10g Round Weight	B63SS	B63ZZ Ball Bearing
ST112	Centering Screw	B73SS	B73ZZ Ball Bearing
ST118L	SB Bellcrank Axle	B415	B415ZZ Ball Bearing
ST122	Damper Screw	SC2X4	M2x4 Cap Head Screw
ST143	Damper valve	SC2X6	M2x6 Cap Head Screw
ST205	Damper Rod	SC2X15	BDL Screw 15 mm
G07	GD2 Satellite Gear	SB2.5X8	M2.5x8 Button Head Screw
G08	GD2 Bevel Gear	SS3X3	M3x3 Set Screw
P01	Ball Joint-1	SS3X4	M3x4 Set Screw
P01X	Ball Joint BDL	SS3X5	M3x5 Set Screw
P02	Ball Joint-2	SB3X5AL	M3x5 Alloy Screw
P03	Arm Ball Cap	SB3X5	M3x5 Button Head Screw
P04	Arm Hasp	SB3X6	M3x6 Button Head Screw
P05	Sway Bar Joint	SB3X8	M3x8 Button Head Screw
P07	Arm Clip	SB3X10	M3x10 Button Head Screw
P12X	Sway Bar Holder	SB3X12	M3x12 Button Head Screw
P13-4	Ball End	SF3X5	M3x5 Flat Head Screw
P14-1-R	Bumper	SF3X6	M3x6 Flat Head Screw
P14-5-R	Top Bumper	SF3X8	M3x8 Flat Head Screw
P14-2	Body Post	SF3X10	M3x10 Flat Head Screw
P15L	Lightweight Foam Bumper	BEL351B	Belt 351mm Bando
P16	Lock Ring	DG1X	Damper Guage Set
P23-R	Outer Battery Holder	STS-A800R	A800R Stickers Sheet

## Optional Parts

Parts#	Description
C204-R+1.0	Suspension Arm Right +1 mm
C204-R-1.0	Suspension Arm Right -1 mm
C204-L+1.0	Suspension Arm Left +1 mm
C204-L-1.0	Suspension Arm Left -1 mm
C07-R	Carbon bumper
C26	Top Stiffener
ST05-R	Damper Rod
ST24M	4,8x8mm Ball Stud
ST24L	4.8x10mm Ball Stud
ST69-15	Progressive Spring Screw
ST69-25	Progressive Spring Screw
ST122-1	Damper Screw
ST147	PS Retainer
AT06	Alloy Antenna Holder
AT13W	Wheel Hex Wide
AT15	Bearing Spacer
AT18	BSSX Steering Limiter
AT21	Pivot Ball
AT139	Fan Holder
AT143	ARB Stiffener
AT144	ULCG Battery Clamp
AM24-R	Servo Holder
AM124	Steering Plate
AM152	SB Steering Stand
BW7	Weight 7g
BW8	Weight 8g
BW10L	Weight 10g
BW22R	Battery Holder 22g
BW27	Rear Stiffener 27 g
BW52R	Battery Holder 52g
C45F-PS	Dampers Brace Front PS
C45R-PS	Dampers Brace Rear PS
DT10-3	Bearing Housing
OR14V	O-ring 4x1 Viton
P40F	Servo Arm (Futaba)
P40K	Servo Arm (KO)
P138LFA	38T Pulley Low Friction
P138S-LFA	Spool 38T Pulley Low Friction
SH3X5X0.1	3x5x0.1mm Shim
SH3X5X0.5	3x5x0.5mm Shim
SH0.25	6x3x0.25mm Spacer
SPR14-R	Center Spring
SPR-P2	Progressive Spring
T01	5.5/4 mm Wrench
T02	Wrench
BSSX	Bellcrank Steering Set
HRB	Horizontal Rear Bodypost Set



**UAB "AWESOMATIX"**  
**Email: [support@awesomatix.com](mailto:support@awesomatix.com)**